

# Series 903K & 904K

## Operating Instructions



Kessler-Ellis Products Co.  
 10 Industrial Way East, Eatontown, NJ 07724  
 Toll Free: 800-631-2165 • Phone: 908-935-1320 • Fax: 908-935-9344  
<http://www.kep.com>

### Electronic Preset Counter Type Series 903K / 904K

#### 1. Description

- 6 digit preset counter, add./subtr., 1 preset (2 presets for 904K)
- bright 2-line LCD display with symbols for activated outputs and current preset values
- count and preset range - 999999 to 999999, (1 decade over or underflow will be indicated by flashing of the display with 1 Hz frequency)
- programmable to operate as a preset counter, timer or frequency meter
- one or two preset values (selectable on 904K) (903K has 1 preset)
- relay or optocoupler outputs
- programming of count functions and operating parameters via front panel keys with menu prompts  
 Side switch secures program settings
- programmable features:
  - operating mode (output signal at zero or at preset point, with or without automatic reset)
  - decimal point
  - polarity of the inputs (NPN or PNP)
  - input mode and multiplying factor
  - output signals to be permanent or timed
  - gate time when programmed as a frequency meter
  - resolution of 0.001, 0.01, 0.1, 1 when programmed as a timer (s, min, h or h:min:s)
- supply voltage 230 VAC, 115 VAC, 48 VAC, 24 VAC or 11...30 VDC
- backlit display (optional, available with 904K only)

#### 2. Inputs

##### 2.1 INP A, INP B

Count inputs; max. count frequency 30 Hz or 10 kHz separately selectable for both inputs via programming switches C and D at the right side of the housing.



Microswitch	INP A		INP B	
	30 Hz	10 kHz	30 Hz	10 kHz
D	ON	OFF		
C			ON	OFF

#### 2.2 Gate

Level input; no counting while this input is activated. If operated as a timer (only h, min and 0.1min resolutions), the decimal point between the 5th and 6th decade flashes while gate input is activated (operating indication).

#### 2.3 Reset

Edge triggered input; resets the counter to zero (adding mode) or to preset value (preset value 2 for 904K)(subtracting mode).

#### 2.4 Key

Level activated keyboard lock input. While this input is activated, it is neither possible to reset the counter nor to change the preset values.

#### 3. Display

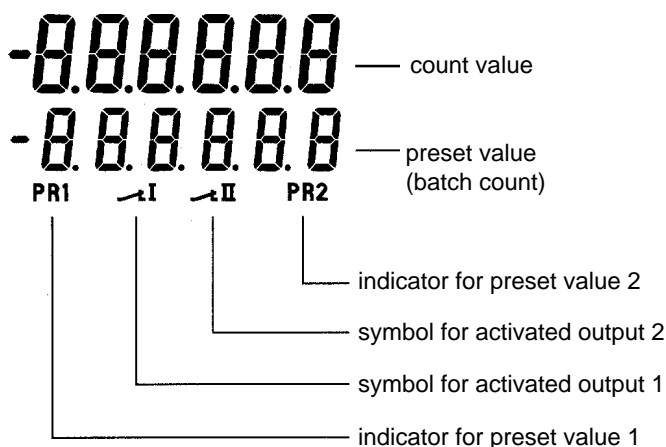

#### 4. Outputs (Programmable; energized or de-energized)

##### 4.1 Output 1 (Second output for 904K)

N.O. Relay (Form A) or Optocoupler (collector & emitter)

##### 4.2 Output 2 (Output 1 for 903K)

SPDT Relay (Form C) or Optocoupler (collector & emitter)

**4.3 Activated outputs** will be indicated by  $\uparrow$ I and  $\uparrow$ II symbols on the display. For safety circuits the operation of the relay, (optocoupler) may be inverted. Thus the relay (optocoupler) will be active at power on and will remain active until the preset ("0") is reached at which point the output will turn "off". For this operation the outputs must be set to  $\neg$  (permanent signal) or  $\neg$ T (timed signal) during the programming routine.

**Caution:** For all operating modes with automatic reset (AddAr, SubAr, AddbAt, SubbAt) output 1 (output 2 on 904K) must have a timed duration. The output does not change if permanent output is selected. (904K auto reset will reset preset 1 if it is set for permanent signal and is active.)

**5. Setting of the operating parameters**

- connect to supply voltage
- set microswitch "A" (right side of the housing) to "ON". Display will show 1st menu item 'Mode'.
- select required function via  $\Delta$ -key
- press P-key to store selected function/enter data and to change over to next menu item.
- select again the required function via  $\Delta$ -key resp. enter data (prescaling factor, duration of timed signal, gate time, resolution) directly via the two arrow-keys.
- After programming the last menu item (permanent or timed signal), set "A" switch to "OFF". Press "P" to step through menu settings to run mode.

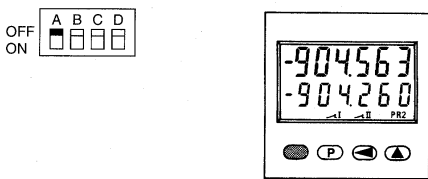

**6. Setting of the operating mode**

**6.1 Selection of basic function**

Set side microswitch "A" to "ON" (down). One of the basic functions will be displayed as follows:

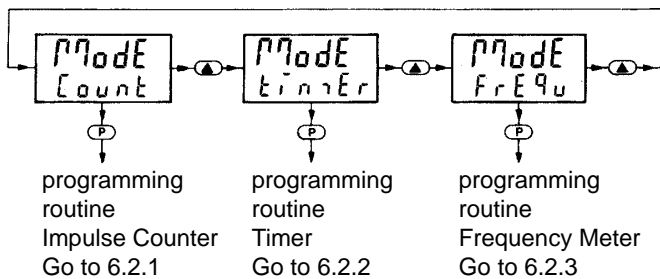

**9. Connections**

**6.2.1 Programming routine Impulse Counter**

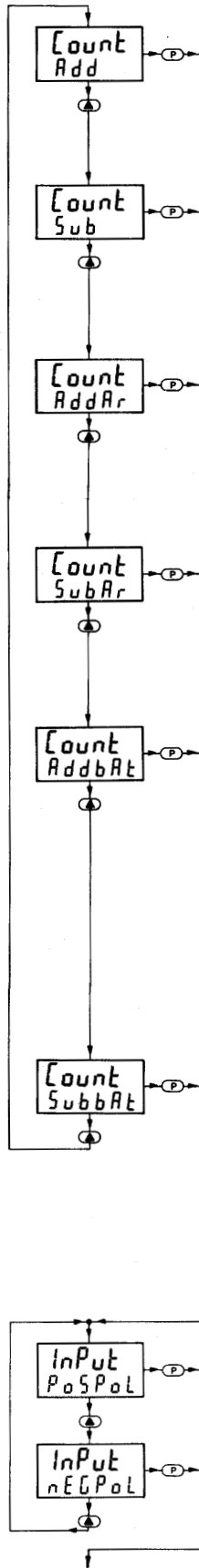

**Adding mode:**  
Up count mode with selected time output when count  $\geq$  preset. External reset to "0".

**Subtracting mode:**  
Down count mode with selected time output when count  $\leq$  "0".  
External reset to preset (preset 2 for 904K)

**Adding mode with auto reset:**  
Up count mode with selected time output at presets. 903K auto resets to "0" at preset 1. (904K auto resets to "0" at preset 2.)

**Subtracting mode with auto reset:**  
Down count mode with selected time output at preset. 903K auto resets to preset 1 at "0" count. (904K preset 1 has selected timed output when count  $\leq$  preset 1. Preset 2 has selected time output at "0" and will auto reset to preset 2.)

**Adding mode with batch counter: (904K only)**  
Up count with selected time output and auto reset to "0" when count  $\geq$  preset 2. A second up preset counter (batch counter, displayed on bottom line) counts the number of cycles of preset 2 and gives a selected time output when batch amount is  $\geq$  preset 1. The front panel reset resets both counters to "0". Remote reset resets only the main counter to "0" (does not reset batch counter).

**Subtracting mode with batch counter: (904K only)**  
Down count with selected time output and auto reset to preset 2 when count  $\leq$  "0". A second up preset counter (batch counter, displayed on bottom line) counts the number of cycles of preset 2 and gives a selected time output when batch amount is  $\geq$  preset 1. The front panel reset sets the counter to preset 2 and the batch counter to "0". Remote only sets the main counter to preset 2 (does not reset batch counter).

**Polarity of the inputs:**  
pospol: positive polarity (PNP) switching to +V (4 to 30 VDC)

negpol: negative polarity (NPN) switching to 0V (0 to 1 VDC)

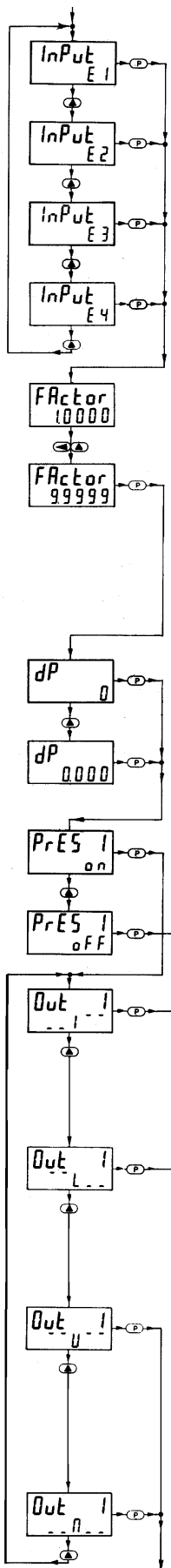

**Input modes:**

**E1:** INP A = count input  
 INP B = count direction input  
 Passive input = Add  
 Active input = Subtract

**E2:** INP A = count input adding  
 INP B = count input subtr.

**E3:** Quadrature input  
 INP A = count input 0°  
 INP B = count input 90°

**E4:** same as E3, but with pulse doubling.  
 Each pulse edge of INP A will be counted.

**Multiplying factor:**

0.0001 ... 9.9999  
 Setting with < and Δ keys  
 Factor 0.0000 won't be accepted  
 Caution! In operating modes Sub, SubAr and SubbAt (output signal at count value = zero) the preset value has to be integerly divisible by the factor, otherwise the counter when reset, will be set to the following integer multiple of the factor.

**Decimal point (only optical function):**

0 = no decimal point  
 0.0 = one decimal place  
 0.00 = two decimal places  
 0.000 = three decimal places

**Preset 1 on-off (904K only)**

on = on (preset 1 & preset 2 active)  
 off = off (preset 1 off, preset 2 active)

**Output modes**

Permanent signal of output 1.  
 Adding mode: Output is activated when count value ≥ preset 1  
 Subtracting mode: Output is activated when count value ≤ "0". (904K: output is activated when count value ≤ preset 1)\*†

Permanent signal of output 1.  
 Adding mode: Output is activated at power on and becomes passive when count value ≥ preset 1  
 Subtracting mode: Output is activated at power on and becomes passive when count value ≤ "0". (904K: output is activated when count value ≤ preset 1)\*†

Timed signal of output 1.  
 Adding mode: Output is active at power on and becomes passive for selected time when unit counts up to preset 1.  
 Subtracting mode: Output is activated at power on and becomes passive for selected time when unit counts down to "0". (904K: passive when unit counts down to preset 1)\*†

Timed signal of output 1.  
 Adding mode: Output becomes active for selected time when unit counts up to preset 1.  
 Subtracting mode: Output becomes active for selected time when unit counts down to "0". (904K: passive when unit counts down to preset 1)\*†

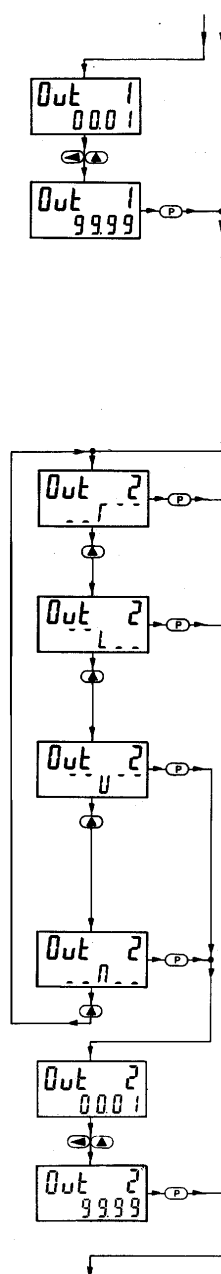

Duration of timed signal of output 1, can be set from 00.01 s to 99.99 s.

\* Activation of relay coil resp. optocoupler when reaching the preset value

\*\* Relay coil becomes dead resp. optocoupler will be turned off when reaching the preset value

**Output 2 (904K only)**

Permanent signal of output 2.  
 Adding mode: Output is activated when count value ≥ preset 2  
 Subtracting mode: Output is activated when count value ≤ "0".\*

Permanent signal of output 2.  
 Adding mode: Output is activated at power on and becomes passive when count value ≥ preset 2  
 Subtracting mode: Output is activated at power on and becomes passive when count value ≤ "0".

Timed signal of output 2.  
 Adding mode: Output is active at power on and becomes passive for selected time when unit counts up to preset 2.  
 Subtracting mode: Output is activated at power on and becomes passive for selected time when unit counts down to "0".\*\*

Timed signal of output 2.  
 Adding mode: Output becomes active for selected time when unit counts up to preset 2.  
 Subtracting mode: Output becomes active for selected time when unit counts down to "0".\*

Duration of timed signal of output 2, can be set from 00.01 s to 99.99 s.

\* Activation of relay coil resp. optocoupler when reaching the preset value

\*\* Relay coil becomes dead resp. optocoupler will be turned off when reaching the preset value

When program is selected, set switch "A" to "off" and press "P" to step through to run mode.

† **904K Units**

When auto reset mode is selected (addAR or subAR) and preset 1 is set for permanent output (┌ or ┘), output 1 (if tripped) will be reset to "power on" state when preset 2 auto recycles.

## 6.2.2 Programming routine Timer

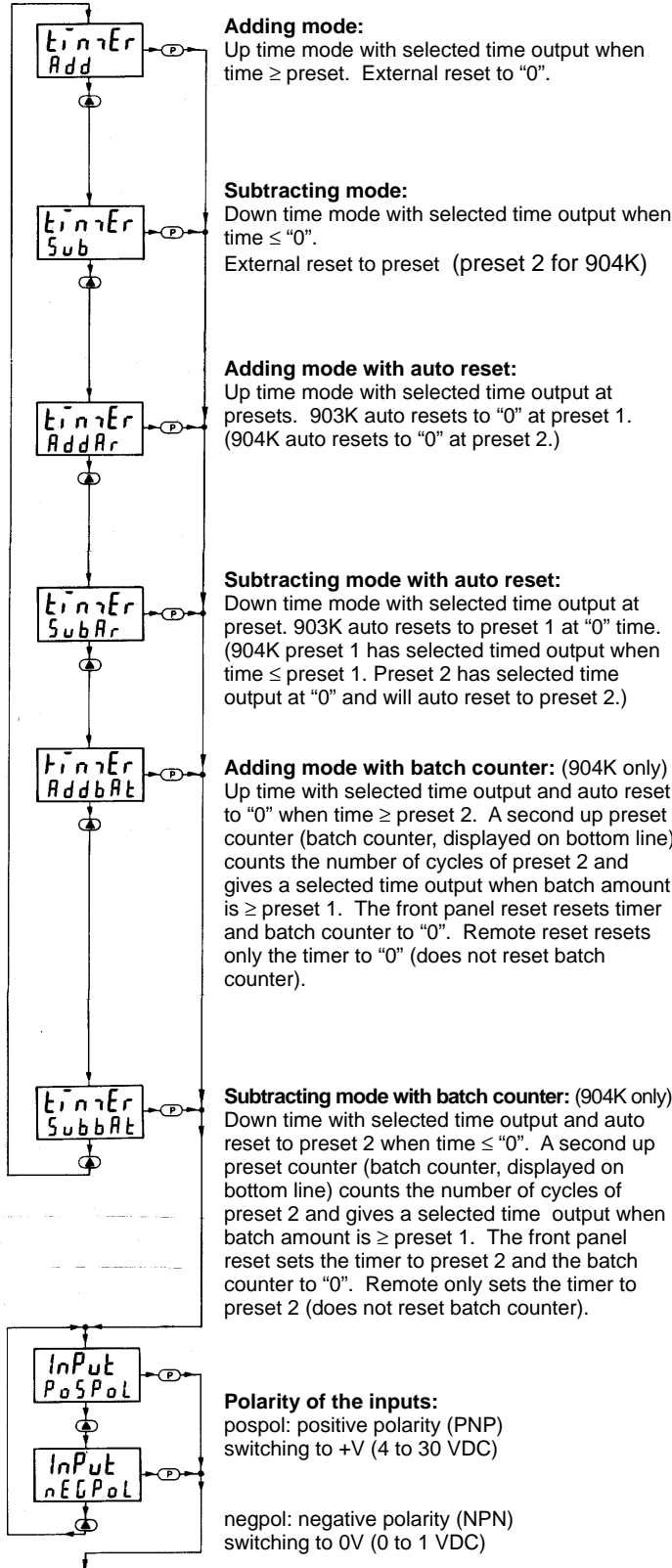

\* Activation of relay coil resp. optocoupler when reaching the preset value

\*\* Relay coil becomes dead resp. optocoupler will be turned off when reaching the preset value

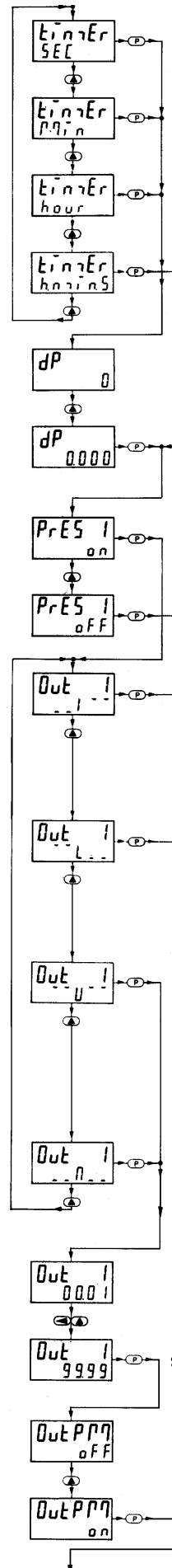

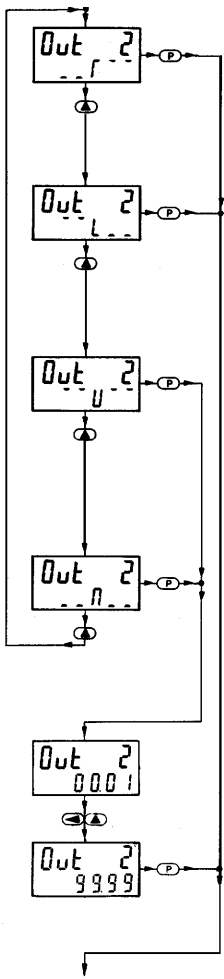

**Output 2 (904K only)**  
 Permanent signal of output 2.  
 Adding mode: Output is activated when time value  $\geq$  preset 2  
 Subtracting mode: Output is activated when time value  $\leq$  "0".\*

Permanent signal of output 2.  
 Adding mode: Output is activated at power on and becomes passive when time value  $\geq$  preset 2  
 Subtracting mode: Output is activated at power on and becomes passive when time value  $\leq$  "0".

Timed signal of output 2.  
 Adding mode: Output is active at power on and becomes passive for selected time when unit times up to preset 2.  
 Subtracting mode: Output is activated at power on and becomes passive for selected time when unit times down to "0".\*\*

Timed signal of output 2.  
 Adding mode: Output becomes active for selected time when unit times up to preset 2.  
 Subtracting mode: Output becomes active for selected time when unit times down to "0".\*

Duration of timed signal of output 2, can be set from 00.01 s to 99.99 s.

When program is selected, set switch "A" to "off" and press "P" to step through to run mode.

**TIME CONTROL**

Activate gate (pin 2-6) to time. To reset and time from one input, activate reset (pin 2-5) and gate (pin 2-6) at the same time.

**NOTE:** Pins 2-3 & 2-4 are not used in timer mode

\* Activation of relay coil resp. optocoupler when reaching the preset value

\*\* Relay coil becomes dead resp. optocoupler will be turned off when reaching the preset value

**6.2.3 Programming routine Frequency Meter**

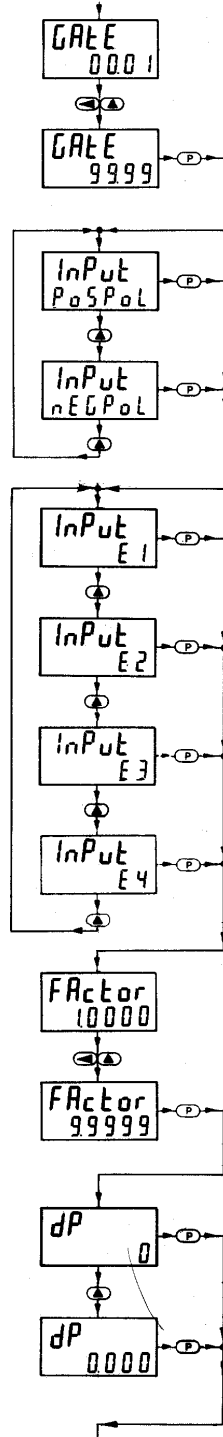

**Gate time** = within this period the incoming pulses will be counted and displayed.  
 Programmable range from 00.01 s to 99.99 s to be entered by < and  $\Delta$  keys. 00.00 won't be accepted

**Polarity of the inputs:**  
 pospol: positive polarity (PNP) switching to +V (4 to 30 VDC)  
 negpol: negative polarity (NPN) switching to 0V (0 to 1 VDC)

**Input modes:**  
**E1:** INP A = count input  
 INP B = count direction input  
 Passive input = Add  
 Active input = Subtract

**E2:** INP A = count input adding  
 INP B = count input subtr.

**E3:** Quadrature input  
 INP A = count input 0°  
 INP B = count input 90°

**E4:** same as E3, but with pulse doubling.  
 Each pulse edge of INP A will be counted.

**Multiplying factor:**  
 0.0001 ... 9.9999  
 Setting with < and  $\Delta$  keys  
 Factor 0.0000 won't be accepted

**Decimal point (only optical function):**  
 0 = no decimal point  
 0.0 = one decimal place  
 0.00 = two decimal places  
 0.000 = three decimal places

**NOTE:** Frequency signals applied to the subtracting input displays "-".  
 The rate value displayed is the net value of both inputs.

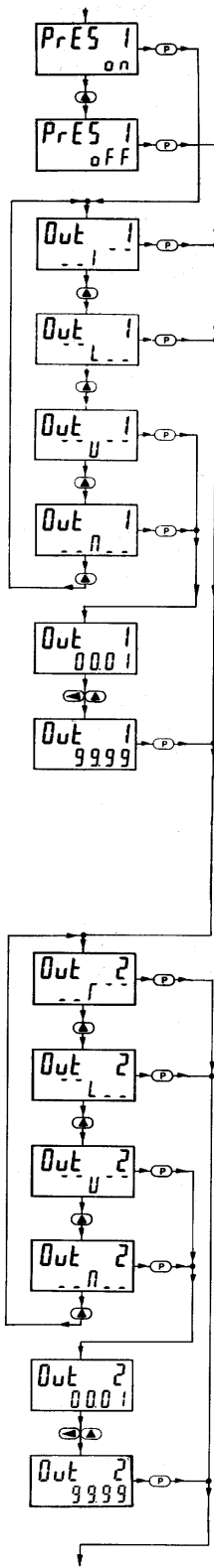

**Preset 1 on-off (904K only)**  
 on = on (preset 1 & preset 2 active)

off = off (preset 1 off, preset 2 active)

Permanent signal of output 1,  
 activated at rate value  $\geq$  preset 1\*  
 de-activates when rate  $<$  preset 1

Permanent signal of output 1, active at power on,  
 becomes passive at rate value  $\geq$  preset 1\*\*  
 re-activates when rate  $<$  preset 1.

Timed signal of output 1 active at power on,  
 becomes passive for selected time each time  
 rate value ramps up to preset 1.\*\*

Timed signal of output 1, activated for selected  
 time each time rate value ramps up to preset 1.\*

Duration of timed signal of output 1,  
 can be set from 00.01 s to 99.99 s.

\* Activation of relay coil resp. optocoupler when  
 reaching the preset value

\*\* Relay coil becomes dead resp.  
 optocoupler will be turned off when  
 reaching the preset value

**Output 2 (904K only)**  
 Permanent signal of output 2,  
 activated at rate value  $\geq$  preset 2\*  
 de-activates when rate  $<$  preset 2

Permanent signal of output 2, active at power on,  
 becomes passive at rate value  $\geq$  preset 2\*\*  
 re-activates when rate  $<$  preset 2.

Timed signal of output 2 active at power on,  
 becomes passive for selected time each time  
 rate value ramps up to preset 2.\*\*

Timed signal of output 2, activated for selected  
 time each time rate value ramps up to preset 2.\*

Duration of timed signal of output 2,  
 can be set from 00.01 s to 99.99 s.

When program is selected, set switch "A" to "off" and press "P" to step through to run mode.

\* Activation of relay coil resp. optocoupler when reaching the preset value

\*\* Relay coil becomes dead resp. optocoupler will be turned off when reaching the preset value

**7. Programming of the Preset Value:**

For 904K, press the "P" button to choose preset 1 (PR1) or preset 2 (PR2). After pressing one of the arrow keys, the leading zero blanking will be suppressed for approx. 4 seconds and the least significant digit of the preset value flashes with a frequency of 1 Hz.

The value of the flashing digit can be increased by using the  $\Delta$  key. Use the  $\leftarrow$  key to step to the next digit. If no key is pressed for 4 seconds, the new preset is loaded and the display returns to the run mode.

**Timed Outputs:** In adding mode, output trips each time value goes up to preset. In subtracting mode, output trips each time value goes down to preset.

**Permanent Outputs:** Outputs trip on and off as value goes up and down through preset.

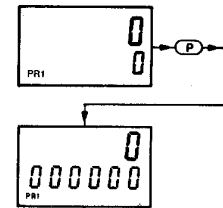

Setting Preset 1

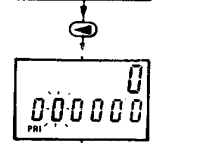

Setting of the 5th decade

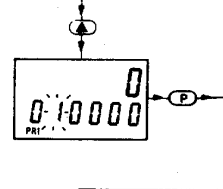

Setting Preset 2

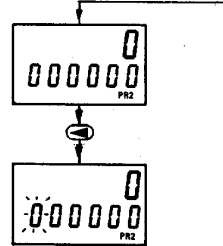

Setting of the 6th decade

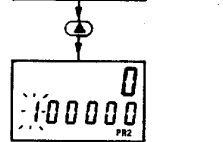

**7.1 Setting of the sign**

Select the sign by using the  $\leftarrow$  key. The sign will start to flash now and can be assigned to the preset value; resp. eliminated by using the  $\Delta$  key. If no key is pressed for 4 seconds, the leading zero blanking will be activated automatically again. Preset value and count value are displayed now with the corresponding sign.

Caution! In case of automatic reset or batch mode, no negative values are to be set for preset 1 of 903K or preset 2 of 904K.

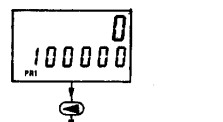

Setting the sign for preset 1

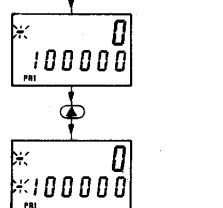

8. Examples for application connections:

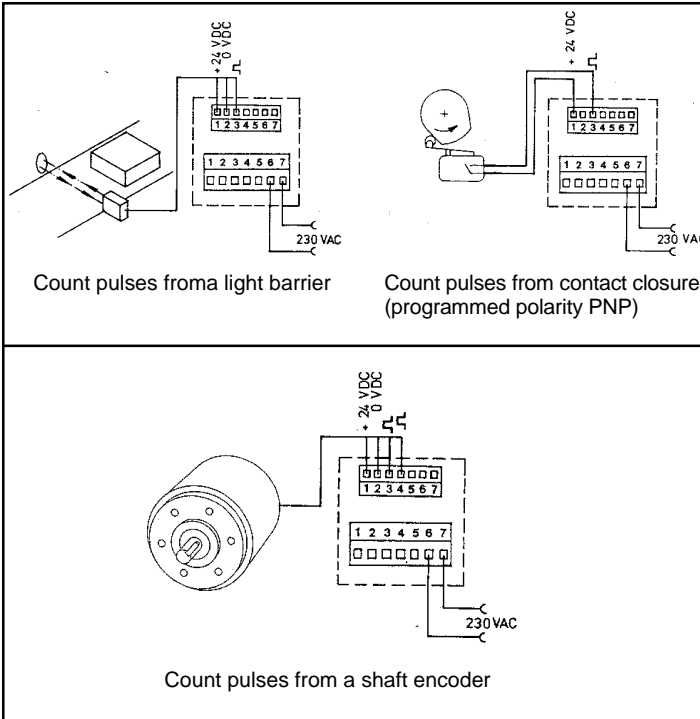

904K Wiring

AC Supply Wiring

TB-1		TB-2	
Term. #	Description	Term #	Designation
1	Relay 1 - C (Opto Collector1)	1	+24VDC Output
2	Relay 1 - NO (Opto Emitter1)	2	0VDC (Ground)
3*	Relay 2 - C (Opto Emitter2)	3	Input A
4	Relay 2 - NO	4	Input B
5*	Relay2 - NC (Opto Collector2)	5	Reset
6	AC Input	6	Gate
7	AC Input	7	Key

DC Supply Wiring

TB-1		TB-2	
Term. #	Description	Term #	Designation
1	Relay 1 - C (Opto Collector1)	1	No Connection
2	Relay 1 - NO (Opto Emitter1)	2	No Connection
3*	Relay 2 - C (Opto Emitter2)	3	Input A
4	Relay 2 - NO	4	Input B
5*	Relay2 - NC (Opto Collector2)	5	Reset
6	(+) 11-30 VDC Supply	6	Gate
7	(-) 0 VDC Supply (Ground)	7	Key

\* The wiring termination of pins 3 & 5 is correct here and on the unit termination label. Pins 3 & 5 may be reversed on some older datasheets.

10. Technical Data:

- Display:** 6 digit, 2-line, 7 segment LCD with sign
- Preset:** Type 904 two preset values  
Type 903 one preset value
- Supply voltage:** 115 VAC, 230 VAC, 48 VAC or 24 VAC (tolerance  $\pm 10\%$ ) or 11 ... 30 VDC
- Count inputs:** 2 count inputs, 4 input modes programmable.
- Input polarity:** programmable (PNP or NPN)
- Input resistance:** 10 kohm
- Max. count frequency:** 10 kHz (Switch selectable 30Hz or 10kHz)
- Min. pulse length of the control inputs:** 5 ms
- Input sensitivity:** Logic "0": 0 to 1 VDC  
Logic "1": 4 to 30 VDC
- Pulse shape:** variable (Schmitt Trigger characteristic)
- Output:** (Programmable output state)  
relay (250 V @ 3A)  
or optocoupler (30VDC/15mA @ 2V, 5mA @ 0.4V)  
903: 1 output : SPDT  
904: 2 outputs: R1 N.O., R2 SPDT
- Transmitter voltage:** 24 VDC, 80 mA  
24 VDC, 60 mA for version with backlit LCD (optional)
- Data retention:** min. 10 years or  $10^6$  memory cycles
- Noise immunity:** EN 50082 part 2

**Noise transmission:** EN 55011 class B

**Operating temperature:** 0...+50°C

**Housing:** 48 x 48 mm DIN

**Protection:** IP 65 (front)

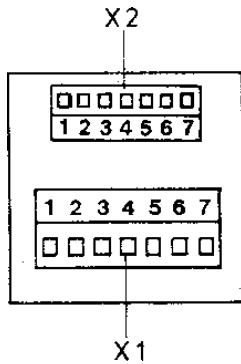

903K Wiring

AC Supply Wiring

TB-1		TB-2	
Term. #	Description	Term #	Designation
1	No Connection	1	+24VDC Output
2	No Connection	2	0VDC (Ground)
3	Relay - C (Opto Emitter)	3	Input A
4	Relay - NO	4	Input B
5	Relay - NC (Opto Collector)	5	Reset
6	AC Input	6	Gate
7	AC Input	7	Key

DC Supply Wiring

TB-1		TB-2	
Term. #	Description	Term #	Designation
1	No Connection	1	No Connection
2	No Connection	2	No Connection
3	Relay - C (Opto Emitter)	3	Input A
4	Relay - NO	4	Input B
5	Relay - NC (Opto Collector)	5	Reset
6	(+) 11-30 VDC Supply	6	Gate
7	(-) 0 VDC Supply (Ground)	7	Key

**Dimensions:**

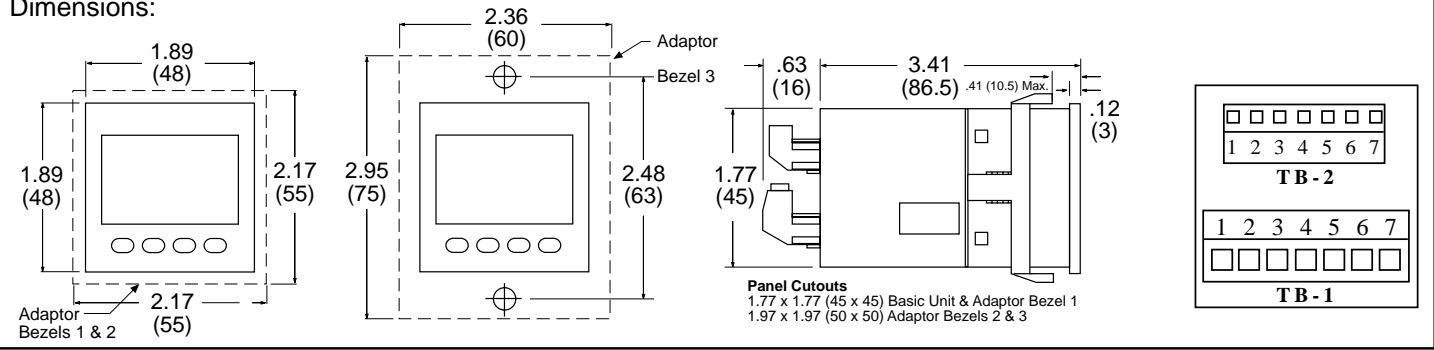

## WARRANTY

This product is warranted against defects in materials and workmanship for a period of two (2) years from the date of shipment to Buyer.

The Warranty is limited to repair or replacement of the defective unit at the option of the manufacturer. This warranty is void if the product has been altered, misused, dismantled, or otherwise abused.

ALL OTHER WARRANTIES, EXPRESSED OR IMPLIED, ARE EXCLUDED, INCLUDING BUT NOT LIMITED TO THE IMPLIED WARRANTIES OF MERCHANTABILITY AND FITNESS FOR A PARTICULAR PURPOSE.

**How To Order:**

<b>EXAMPLE</b>	<b>904K</b>	<b>A</b>	<b>0</b>	<b>A</b>	
<b>Series</b>					
903K = Single Output					
904K = Dual Outputs					
<b>Operating Voltage</b>					
A = 115 VAC					
B = 230 VAC					
C = 11 to 30 VDC					
D = 24 VAC					
E = 48 VAC					
<b>Outputs</b>					
0 = Relay					
1 = Opto-Isolated collector and emitter					
<b>Options</b>					
- Blank if None					
A = Backlit LCD Display (904K only)					



Kessler-Ellis Products Co. 10 Industrial Way East, Eatontown, NJ 07724  
 Toll Free: 800-631-2165 • Phone: 908-935-1320 • Fax: 908-935-9344