

RTP

Pulse Input Ratemeter and Totalizer

INSTALLATION & OPERATING INSTRUCTIONS



<http://www.kep.com>

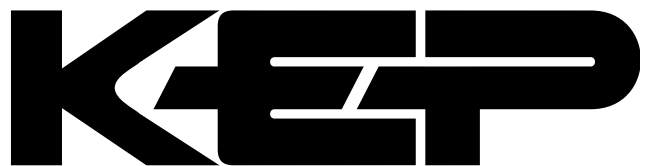

KESSLER-ELLIS PRODUCTS CO.

10 Industrial Way East

Eatontown, NJ 07724

Telephone: (732) 935-1320

Toll Free: (800) 631-2165

Fax: (732) 935-9344

Proprietary Notice

The information contained in this publication is derived in part from proprietary and patent data. This information has been prepared for the expressed purpose of assisting operating and maintenance personnel in the efficient use of the instrument described herein. Publication of this information does not convey any rights to use or reproduce it or to use for any purpose other than in connection with the installation, operation and maintenance of the equipment described herein.

Copyright 1990
Printed in USA. All Rights Reserved.



This instrument contains electronic components that are susceptible to damage by static electricity. Proper handling* procedures must be observed during the removal, installation, or handling of internal circuit boards or devices.

*Handling Procedure

1. Power to unit must be removed.
2. Personnel must be grounded, via wrist strap or other safe, suitable means, before any printed circuit board or other internal device is installed, removed or adjusted.
3. Printed circuit boards must be transported in a conductive bag or other conductive container. Boards must not be removed from protective enclosure until the immediate time of installation. Removed boards must be placed immediately in protective container for transport, storage, or return to factory.

Comments

This instrument is not unique in its content of ESD (electrostatic discharge) sensitive components. Most modern electronic designs contain components that utilize metal oxide technology (NMOS, CMOS, etc.). Experience has proven that even small amounts of static electricity can damage or destroy these devices. Damaged components, even though they appear to function properly, may exhibit early failure.

TABLE OF CONTENTS

SAFETY INSTRUCTIONS	1
DESCRIPTION & SPECIFICATIONS	2
MOUNTING	3
WIRING	3
PROGRAMMING MENU	5
PROGRAMMING FLOWCHART	7
ANALOG OUTPUT CALIBRATION	13
SOLDER JUMPERS	13
WARRANTY	14
DECODING PART NUMBER	14



SAFETY INSTRUCTIONS

The following instructions must be observed.

- This instrument was designed and is checked in accordance with regulations in force EN 60950 (“Safety of information technology equipment, including electrical business equipment”).
A hazardous situation may occur if this instrument is not used for its intended purpose or is used incorrectly. Please note operating instructions provided in this manual.
- The instrument must be installed, operated and maintained by personnel who have been properly trained. Personnel must read and understand this manual prior to installation and operation of the instrument.
- The use of an external line fuse is recommended. Add or replace the external fuse with the following specified type and rating only:

<u>Input Power</u>	<u>Recommended Fuse</u>
115 VAC	100 mA slow blow fuse
230 VAC	50 mA slow blow fuse
12-24 VDC	250 mA slow blow fuse

Disconnect power supply before adding or replacing fuse!

- The manufacturer assumes no liability for damage caused by incorrect use of the instrument or for modifications or changes made to the instrument.

Symbols Used On Unit

<u>Number</u>	<u>Symbol</u>	<u>Publication</u>	<u>Description</u>
1		IEC 417, No. 5031	Direct current
2		IEC 417, No. 5172	Equipment protected throughout by DOUBLE INSULATION or REINFORCED INSULATION (equivalent to Class II of IEC 536—see annex H)
3		ISO 3864, No. B.3.1	Caution (refer to accompanying documents)

Technical Improvements

- The manufacturer reserves the right to modify technical data without prior notice.

DESCRIPTION & SPECIFICATIONS

DESCRIPTION:

The RTP is a presettable Ratemeter and Totalizer from two pulse inputs. It can show rate and total at the same time on the 2 X 16 backlit LCD display. Both inputs can have up to 16 point linearizing k factors. The unit can be connected in a network for Data Acquisition.

SPECIFICATIONS:

INPUT POWER: AC: 110 V or 220 V; 6.5 VA AC
DC: +24 VDC ; 250 mA max.

THRESHOLD: High: 4-24 VDC; Low: < 1Vdc or open

INPUT A: Count Input, 5 kHz max.

INPUT B: Count Input, 5 kHz max.

INPUT C: Control Input

INPUT D: Control Input

INPUT E: Control Input (Not Used with RS485)

NOTE: AC powered units have isolated inputs. DC units share -DC with input common.

OUTPUT POWER: +20VDC @50 mA (unreg), +/- 15%

DISPLAY: 2 lines of 16 characters, backlit LCD (character size: 2.95mm x 5.55mm)

BEZEL: NEMA 4/IP65 rated membrane keypad

INDICATORS: Two LED's to indicate control output status. (Red = Output A, Green = Output B)

MEMORY: NVRAM retains data on power failure

TEMPERATURE: Operating : 0 to 50 degrees C
Storage : -40 to 90 degrees C

HUMIDITY: 10% to 90% (Non condensing)

SIZE: Bezel: 103mm X 55 mm; Depth: 97 mm

PANEL CUTOUT: 92 mm X 45 mm (1/8 DIN size cutout)

IMMUNITY TO ESD: Level 3 per IEC1000-4-2

IMMUNITY TO TRANSIENTS: Level 3 per IEC1000-4-4

RADIATED SUSCEPTIBILITY: Level 3 per IEC1000-4-3

EMISSIONS: EN55011 CISPR A

PULSE INPUTS

The RTP can accept two pulse inputs (A&B). It computes rate and total of A, B, A+B and A-B. For both inputs the user can define up to 16 points of "k" factors. This allows linearization of the displayed rate, which is useful in improving the accuracy of the flowmeter.

The rate is computed within 300 ms per input. To stabilize the rate display, the user can select normalizing factor, which allows weighted average to be shown. Moreover, for rate displays, a time delay of up to 25 seconds can also be selected.

CONTROL INPUTS

The RTP has three Control Inputs, i.e. Input C, Input D and Input E (Only C & D with RS485 option). Each input can be configured to start/stop each counter or reset each counter and Control Output. These inputs can also perform different control actions like printing on serial port, lock unit and freeze display.

RESET OPTIONS

The entire unit, i.e. all counters and control outputs, or Counter A, Counter B, Counter A+B, Counter A-B, Control O/P A and Control O/P B can be individually programmed to be reset on pressing the front panel RST key and also by a positive edge signal to any of the Control I/Ps C, D and E.

SERIAL COMMUNICATION

The serial strobed port can be used for serial printing of Total or Rate data with descriptors. The unit can also communicate with a master device through a Modbus-RTU protocol. The data given for each parameter is in IEEE float format comprising of 2 words. The unit can be connected in a network. Order Option 1 is RS-232 level format; Order Option 2 is RS-422/485 level format.

CONTROL OUTPUTS

The RTP has the following Control Outputs:
RELAY / O.C.: 2 N.O. relays of 5 A and 250 V OR
2 Open Collector Outputs;
100 mA maximum.

ANALOG OUTPUT:

Type: 4-20 mA output.
Accuracy: ± 50µA worst case.
This Analog O/P can be programmed to track any parameter. Reverse tracking O/P is also available.

PRESETS: The unit supports five counters, i.e. Counter A, Counter B, Counter A+B, Counter A-B and Grand Total. The counters can either be reset to zero or disabled. Relays can be activated by any of the Total or Rate values. If a Total preset activates the relay, the user can select an output duration of 0.1 to 99.9 seconds with instant auto reset to "0". A 00.0 duration keeps the relay activated until externally reset. If both presets are assigned to same counter, with Relay A duration set to 00.0 and Preset A lower than Preset B, Relay A pulls in at Preset A and drops out when Preset B (having a duration other than 00.0) pulls in. Counter recycles immediately, and Relay B stays activated for the selected duration.

If activated by rate, the relay pulls in at High Preset or above and remains on until rate falls below Low Preset.

LOCKOUT: The unit program and presets can be protected with a lock code to prevent unauthorized front panel changes. This code can be assigned with a maximum of 4 digits and is user selectable. It can be entered through front panel LOCK key or by configuring any of the Control I/Ps to "Lock unit". Alternate entry of the lock code or pulses to that I/P will lock or unlock the unit.

MOUNTING

HOW TO MOUNT:

Slide the body of the unit through the rubber gasket. Insert the unit into the panel. Slide the brackets up the groove to press against the back of the panel. Insert the screws into the rear of the brackets.

Tighten the screws evenly and alternately. A panel less

than .1" may distort if the clamps are screwed too tightly. Do not over tighten! A normal level of torque is required. Maximum torque should be 3" pounds.

The panel must be parallel to the bezel to assure proper seal. Unit seals to NEMA 4/IP65 if properly mounted.

DIMENSIONS:

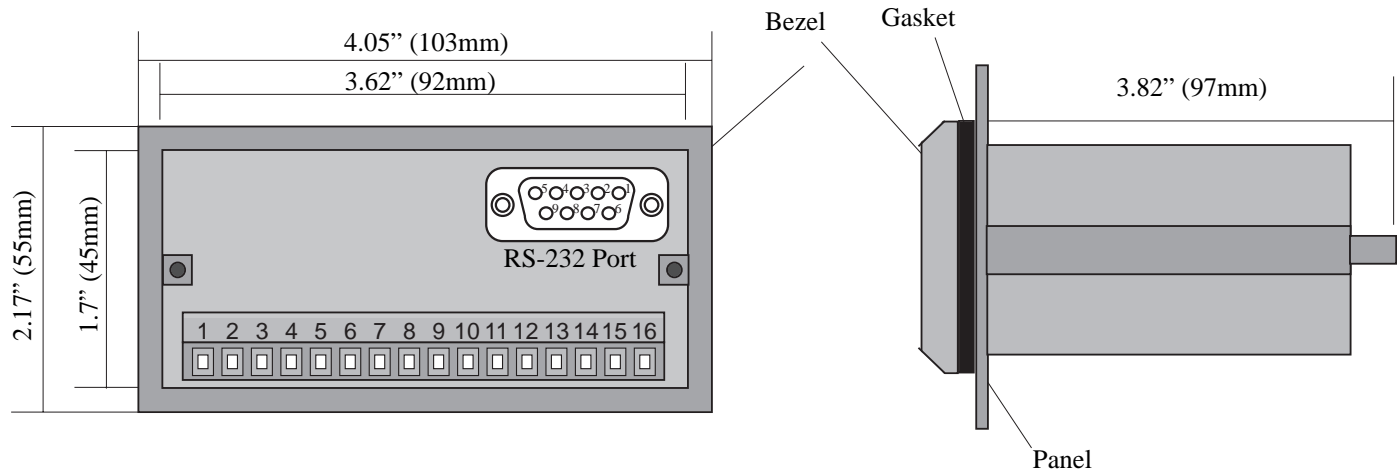

WIRING

WIRING CONSIDERATIONS:

AC / DC CONNECTIONS:

NOTE: Connect power only after other connections are finished. Do not touch the live AC power terminals. The unit has been designed with an isolated AC input, therefore polarity is not a concern for the AC power.

This Product complies with requirements of the European Community Directive 89/336/EEC [Electromagnetic Compatibility]. However, electrical noise or intense electromagnetic fields in the vicinity of the unit may disturb the microprocessor. Users should exercise care and should take proper precautions to avoid microprocessor disturbance.

Four common sources of noise are:

1) AC power line noise- The input power lines should not be common to power lines for motors, pumps, contactors, etc. If the unit cannot be connected to an electrically clean power source, an inductive load suppressing device (MOV as GE#V130LA1 or Resistor Capacitor as Paktron# .2uf/220 ohm @ 400V) can be installed. Although locating the suppressor across the AC supply at the unit should help, best results are obtained by connecting the suppressor across the leads of the "load" at the device causing the spikes.

2) Input line noise- The noise is carried on the input and DC ground lines. Make sure the input wires are not run into the unit in a bundle with power input lines. We recommend using shielded cable. Connect the shield to DC ground of the unit and "earth" at one point in the circuit preferably at the DC ground terminal of the unit.

3) Output lines- The unit has two open collector outputs and two optional relay outputs. When these outputs are used to run external relays or solenoids, spikes can be generated upon activation. This noise can spread through the instrument causing operating problems. If the source is a D.C. operated device, a general purpose diode (IN4004) placed across the solenoid prevents electrical noise spikes. Connect the cathode (banded side) to the more positive side of the coil. If the source is an A.C. operated device, use a Resistor Capacitor or MOV across the coil.

4) 20 VDC (unregulated) output supply- Noise can be generated on the 20 VDC output supply if it is used to drive inductive loads or if the current draw exceeds 50mA. Insure that all inductive loads have a diode (such as IN4004) across the coil and that the current does not exceed 50mA.

WIRING (CONTINUED)

TERMINAL DESIGNATIONS:

- 1 • AC1 (115 VAC)
- 2 • AC2 (115 VAC)
- 3 • RELAY B
- 4 • COMMON
- 5 • RELAY A
- 6 • COMMON
- 7 • (+) 20VDC OUT (50mA) (unregulated)
- 8 • (-) 20VDC OUT (50mA) (unregulated)
- 9 • ANALOG O/P (+)
- 10 • ANALOG O/P (-)
- 11 • CTRL I/P E
- 12 • CTRL I/P D
- 13 • CTRL I/P C
- 14 • PULSE I/P B
- 15 • PULSE I/P A
- 16 • INPUT GND

COMMUNICATION PORT TERMINAL DESIGNATIONS:

RS-232 Port: (DB9 Female)

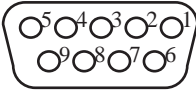

- 1 • N.C.
- 2 • Transmit
- 3 • Receive
- 4 • N.C.
- 5 • Ground
- 6 • Strobe
- 7 • N.C.
- 8 • N.C.
- 9 • N.C.

RS-485 Port: (DB9 Female)

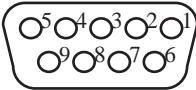

- 1 • Transmit B (-)
- 2 • Receive B (-)
- 3 • N.C.
- 4 • N.C.
- 5 • Ground
- 6 • N.C.
- 7 • N.C.
- 8 • Receive A (+)
- 9 • Transmit A (+)

TYPICAL WIRING HOOKUPS:

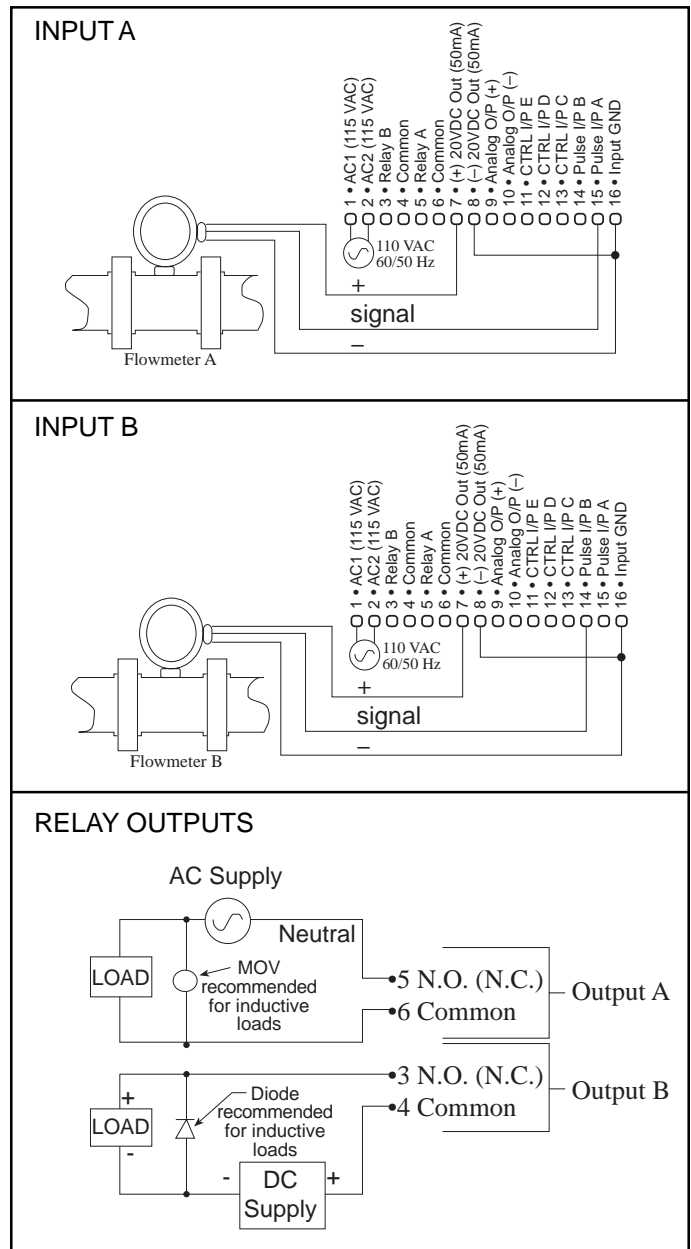

PROGRAMMING MENU

Main Menu:

The Main menu consists of the following steps: Define list of parameters used, Configure Inputs, Setup Counters, Setup Ratemeters, Setup Relays / O.C., Setup Security, Setup 4-20mA Output, Setup Comm Port, Define reset options and Back to RUN mode (or Exit programming). The PROG key allows scrolling through these steps. All these steps are given in brief below:

Define list of parameters used:

The unit is capable of showing nine different parameters. The parameters are the readings *RTP* gives after a pulse input is given to it. The parameter names are fixed in **Default Mode** and are user programmable in **Message Mode**.

The parameter names in Default Mode are:

Rate A, Rate B, Rate A+B, Rate A-B, Total A, Total B, Total A+B, Total A-B and Gr. Total.

The parameter names in Message Mode are user definable.

The length of these user defined names can be upto nine characters. Valid characters are SPACE, A-Z, a-z, 0-9, /.

The menu also enables the user to define the sequence in which the parameters are to be viewed at Run time and the no. of digits after the decimal point (0-3). It also enables the user to program the message for each parameter.

Configure Inputs :

The unit has five inputs, two of which are pulse inputs and the remaining three are control inputs. The two pulse inputs are **Input A** and **Input B**. They can be programmed to be either linear or non-linear.

For linear input a six digit multiplier scaling factor has to be entered (.00001 to 999999). This scaling factor is constant for a linear input. For a non-linear input the scaling factor is different at different frequencies so the points (Frequency, Factor) have to be entered. The unit supports a maximum of sixteen such points. Input B is normally a separate input with separate scaling. It can also be programmed as a control input for up counting or down counting of Total A. A High on Input B makes Total A count up and a low on Input B makes Total A count down.

The remaining three inputs C, D and E are control inputs and can be programmed to control actions such as start counting, reset counting, stop counting, freeze display, lock unit and print activities.

When freeze display is activated (or a pulse is applied to the control input which is configured to freeze display) the unit stops refreshing the display. The unit continues to run in the background.

Setup Counters:

RTP has five counting parameters:

Parameter	Default name	Function
Counter A	Total A	Counts pulses on A
Counter B	Total B	Counts pulses on B
Counter A+B	Total A+B	Adds counter A & B
Counter A-B	Total A-B	Subtracts counter B from counter A
Grand Total	Grand Total	Tracks any of the above four on which it is programmed to be dependent.

Each counter can be reset to zero or disabled. The Grand Total is programmable and can be set to follow any of the remaining counters.

Setup Ratemeters :

The parameters Rate A, Rate B, Rate A + B, Rate A - B can be programmed to be rate/seconds, rate/minutes, rate/hours. The user can use custom scaling if the units are different than RPS, RPH, RPM e.g. rate/day, so that the rates can be converted to engineering units. The custom scaling factor can be of 6 digits ranging from 0.00001 to 999999. The normalizing factor ranging from 0.1 to 99.9 can be programmed.

Normalizing Equation:

$$\frac{(\text{Old Data} \times \text{"Normalizing Factor"} + \text{New Data})}{(\text{"Normalizing Factor"} + 1)}$$

For rate display, a time of up to 25 seconds can also be applied.

Setup Relays:

The unit has two control outputs NO/NC relay A or Open Collector A and NO/NC relay B or Open Collector B. The control outputs can be programmed to track any of the nine parameters and can also be programmed to operate in **Timed Mode** (for count) or **Hysteresis Mode** (for rate).

In Timed mode (count) a low preset value or a high preset value can be entered. If a **low preset** value is entered then the control output will energize whenever the value of the parameter, which the control output is tracking goes **below** the preset value. If a **high preset** value is entered then the control output will energize whenever the value of the parameter, which the control output is tracking goes **above** the preset value. In Timed mode (count) after low preset or high preset have been entered unit will ask for reset time (the time duration that the control output will remain energized). Set time from 0.1 to 99.9 sec. with auto reset of counter. If set to 00.0, count continues and output is latched until reset by external or front panel reset.

In Hysteresis mode (rate) **both** the high preset and low preset for the Hysteresis have to be entered. The control relay will activate when the rate parameter is **equal to** or **exceeds** the high preset. The relay will remain energized until the rate parameter fall **below** the low preset.

PROGRAMMING MENU (CONTINUED)

Setup Security:

Unauthorized front panel changes can be prevented by entering a user selectable four digit code. The unit can be in LOCK ALL or LOCK PROGRAM mode. The unit can be locked while unit is running by pressing the LOCK key three times continuously in one second. If any of the control input (C, D, E) is configured as to LOCK UNIT then the unit can be locked by only giving a pulse at that input and not by pressing the LOCK key. In LOCK PROGRAM mode only the runtime presets are accessible through front panel. In LOCK ALL mode, programming and the runtime presets are not accessible.

Setup 4-20 mA Analog Output :

The unit gives a 4-20 mA analog output and it can be programmed to track any of the nine parameters. The unit can be programmed for reverse tracking (4mA value higher than 20mA value). The analog output is isolated. Compliance voltage must be 3 to 24 VDC. Accuracy $\pm 50\mu\text{A}$ worst case.

Setup Comm port :

In this menu, the unit can be assigned a unique ID and the communication parameters, i.e. baudrate and parity. The serial port can be used for serial printing or also for data acquisition. The unit can communicate with a master device through a Modbus-RTU protocol. The addresses for all nine parameters that can be read from the unit are as follows (the data given for each parameter is in IEEE float format comprising of 2 words):

Rate A	100	Total A	500
Rate B	300	Total B	700
Rate A+B	900	Rate A-B	1100
Total A+B	1300	Total A-B	1500
Grand Total	1700		

Define Reset Options:







In this menu either the entire unit (all counters and control outputs) or Counter A, Counter B, Counter A + B, Counter A - B, Relay A / Open Collector A or Relay B / Open Collector B can be individually programmed to be reset on pressing the front panel RST key or by positive edge signal to selected control input.

Back to RUN mode

Exit programming :

Pressing ENT at this menu exits programming mode and the unit enters the Run mode.

FRONT PANEL OPERATION

KEYPAD FUNCTIONS		
KEY	Run Mode	Program Mode
	Enter The Programming Mode	Toggles between menus
	VIEW key scrolls through the selected viewing parameters	Left key shifts digits in number entry/characters in message mode
	PRE A key allows Preset A to be changed if unit is not locked	Up key increments digits/characters
	PRE B key allows Preset B to be changed if unit is not locked	CLR key clears the numeric field
	Lock Key allows the entry of a lock code to lock/unlock the unit	ENT key saves changes and steps to next menu
	RST Key resets counters (with/without confirmation)	Unit comes out of programming at any level (stores all data entered)

RTP PROGRAMMING FLOWCHART

Define List of Parameters Used

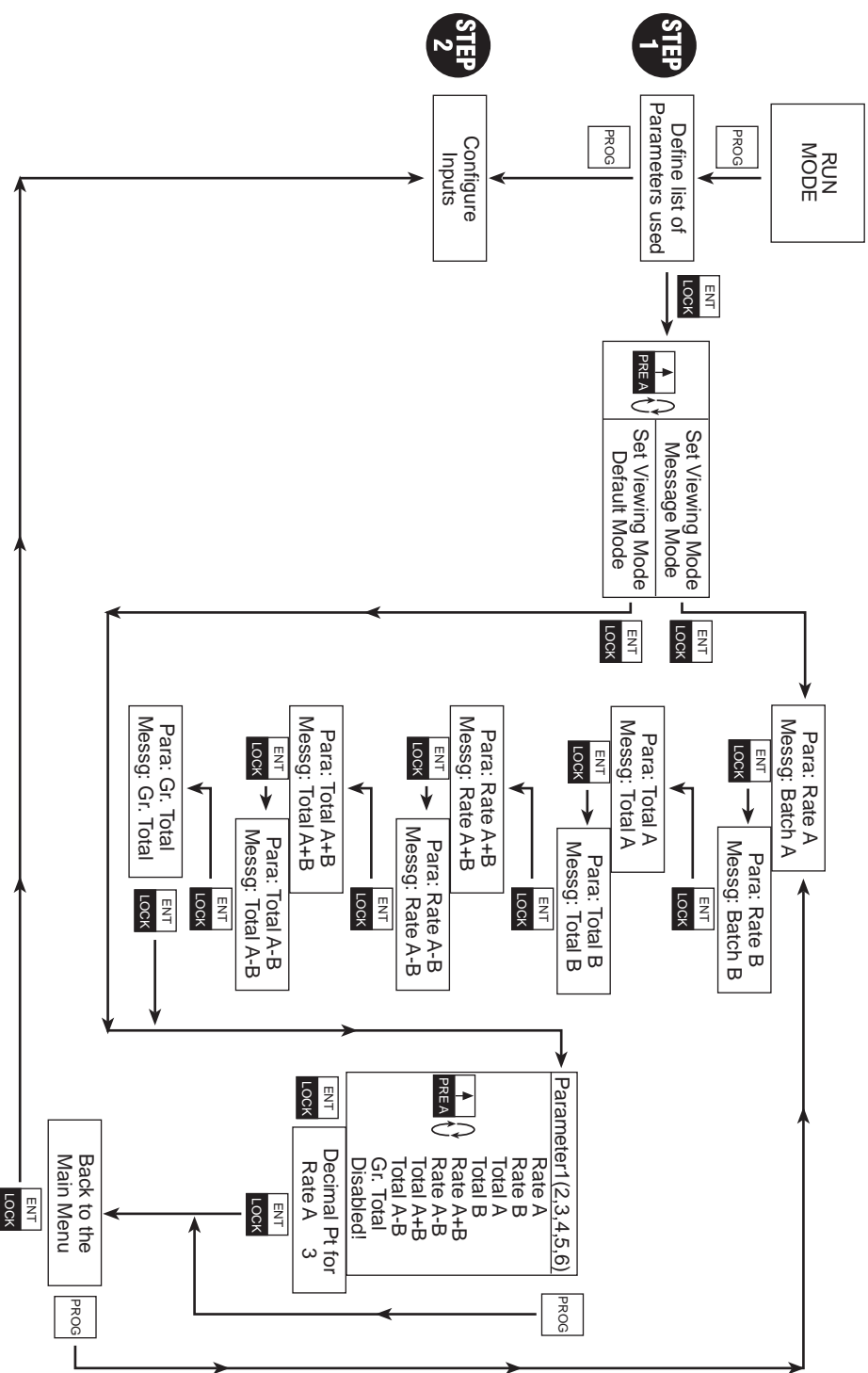

RTP PROGRAMMING FLOWCHART (continued)

Setup Counters

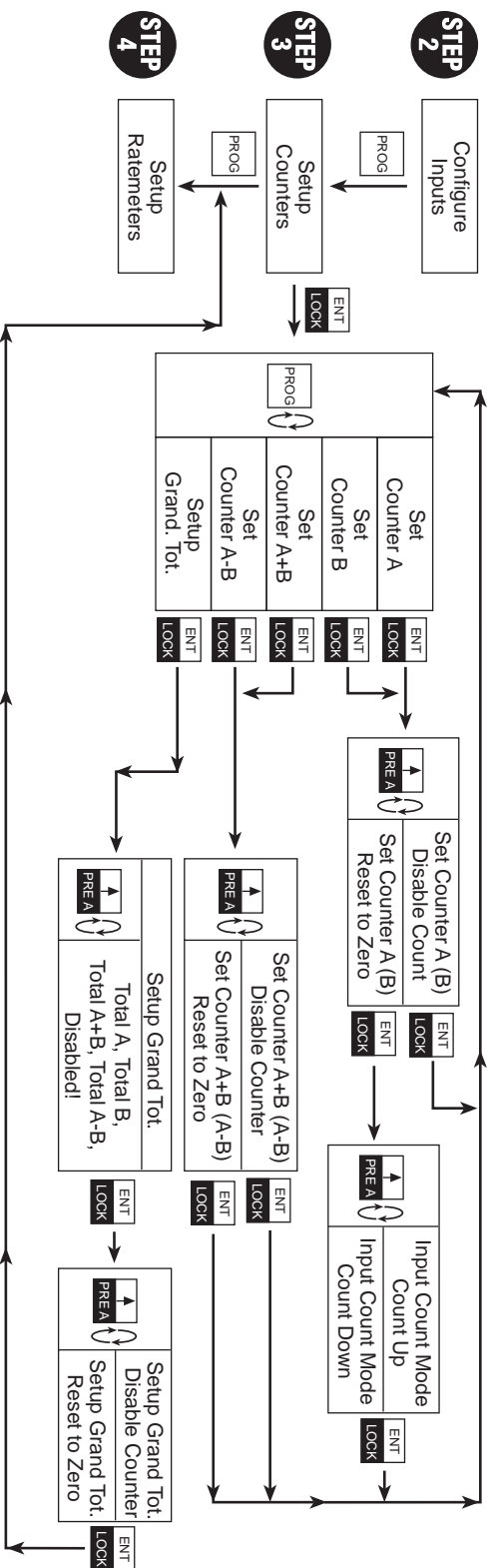

Setup Ratemeters

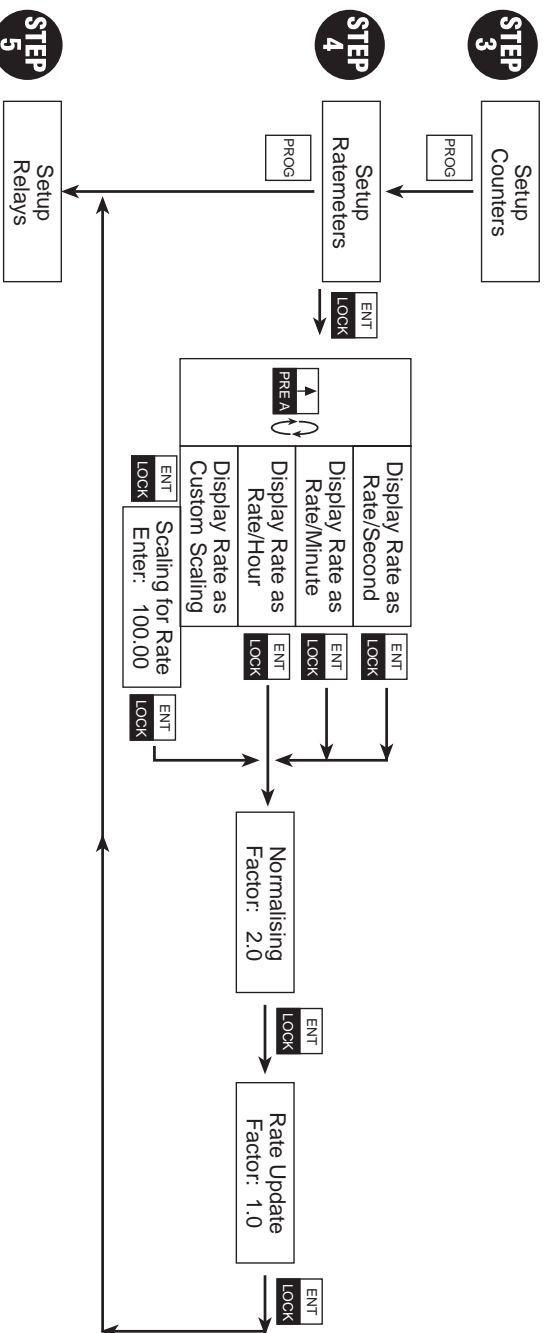

RTP PROGRAMMING FLOWCHART (continued)

Setup Relays

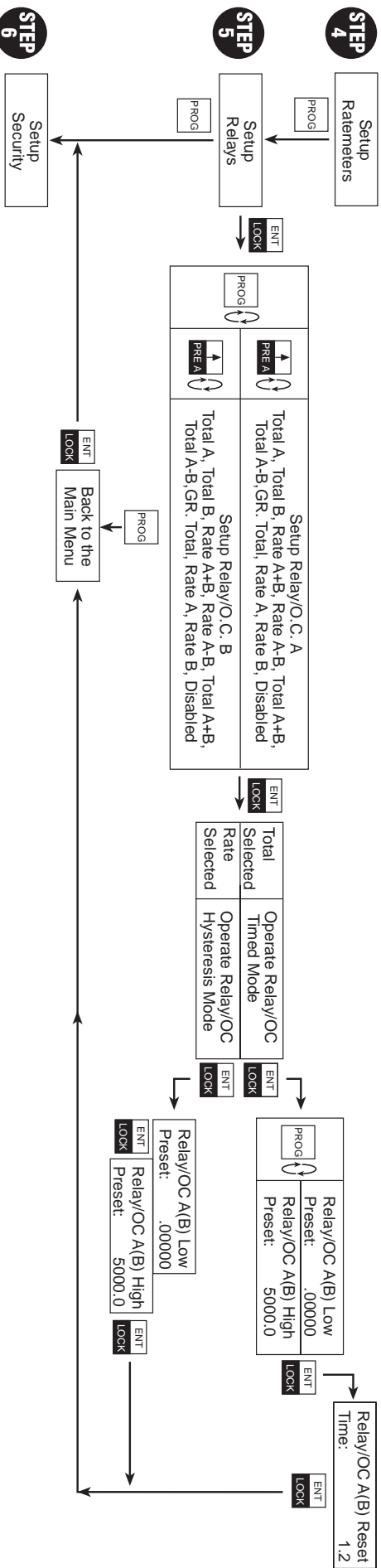

Setup Security

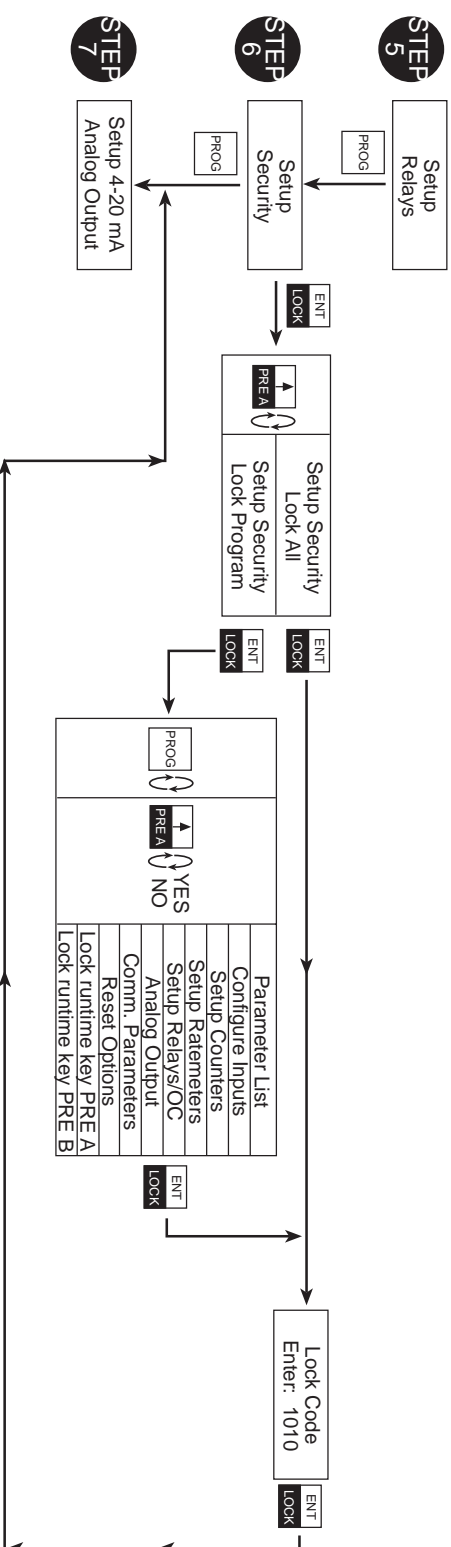

RTP PROGRAMMING FLOWCHART (continued)

Setup 4-20 mA Output

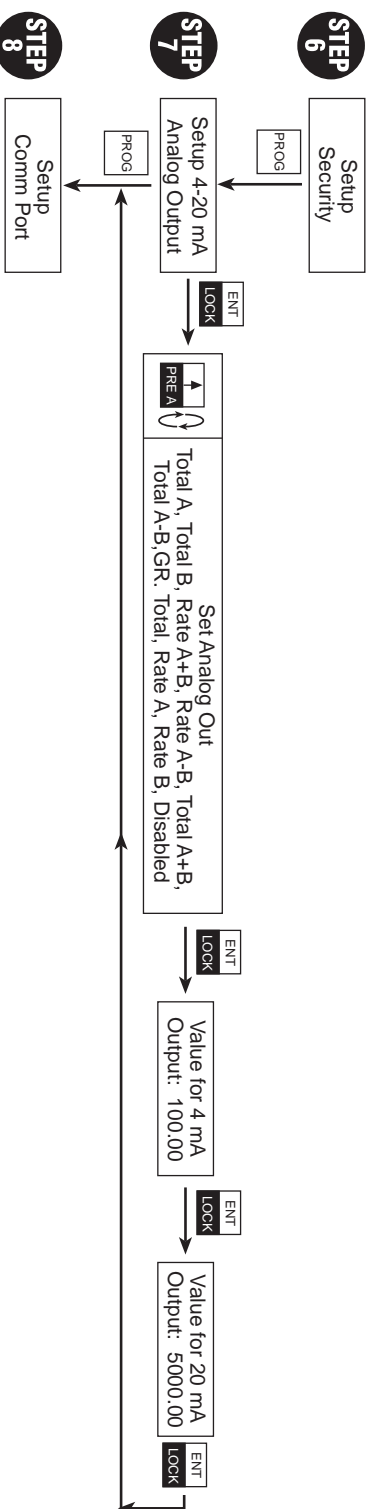

Setup Comm Port

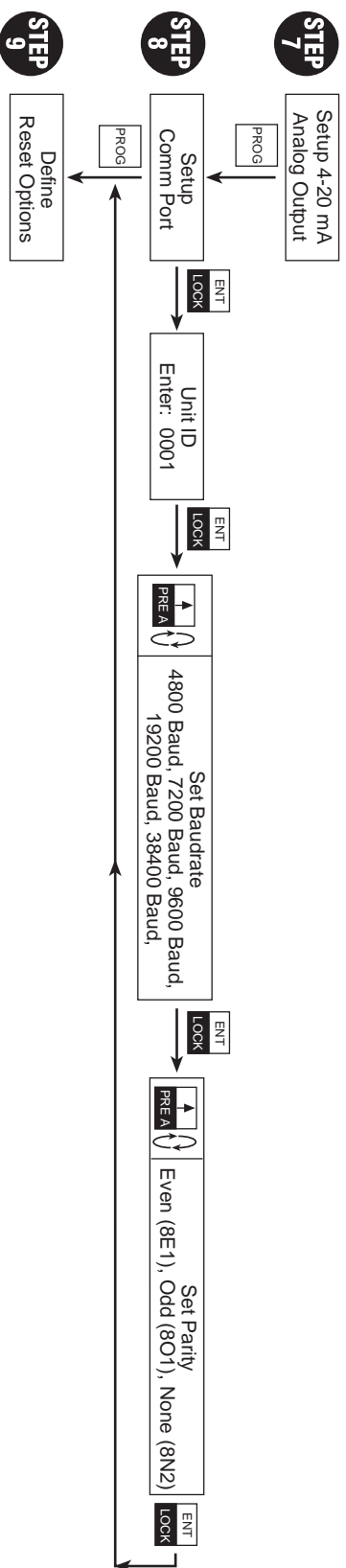

RTP PROGRAMMING FLOWCHART (continued)

Define Reset Options

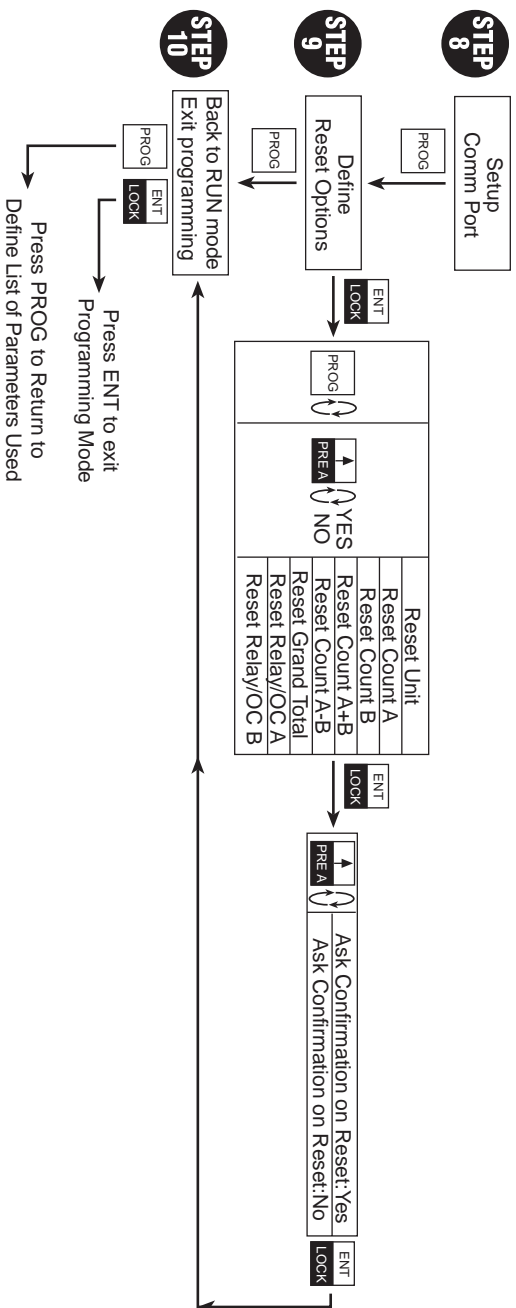

ANALOG OUTPUT CALIBRATION

Analog Output Calibration Procedure:

The calibration of the *RTP* can be done in the following way :

Connect the following circuit to terminal pins 11 and 12, i.e Analog O/P (+) and Analog O/P (-).

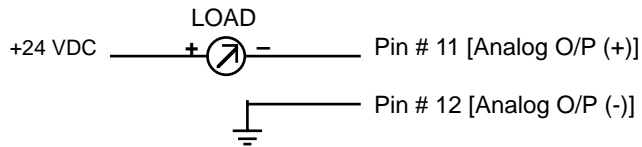

Press the **PROG** key immediately at power-up to enter the Calibration mode.

The unit first displays

Calibrate Analog Output

The unit then displays

Outputting 4mA
Pre A:+ Pre B:-

Calibrate the unit for 4 mA. Use key

↑

 to increase the O/P current and key

CLR

 to decrease the O/P current.

Press

ENT

 key and the next display is

Outputting 20mA
Pre A:+ Pre B:-

Calibrate the unit for 20 mA. Use the same keys as stated above to increase / decrease the O/P current.

NOTE TO OUR CUSTOMER

KEP is dedicated to providing complete customer service and customer satisfaction. If you have any comments or criticisms about how to improve this manual, please make a note of the problem/improvement and notify us. We are always open to new ideas and improvements. So please let us know your ideas and comments.

Call us toll free: 800-631-2165

Decoding Part Number

Example: RTP A 3 1

Series: _____

 RTP= Pulse Input Ratemeter
 Totalizer

Operating Voltage: _____

 A= 110 VAC \pm 15%
 B= 220 VAC \pm 15%
 *C= 24 VDC

Input: _____

 3= Standard, 4-30 VDC simultaneous inputs
 *3MB= Mag. Input, inputs A & B 30mV input

Options: _____

 1= RS-232, 3 Control Inputs (not available with RS-485)
 *2= RS-485, 2 Control Inputs (not available with RS-232)
 *3= Open Collector Output (no relays)
 *A= 4-20 mA Out (Can be ordered with options 1 or 2)
 * Special Order

WARRANTY

This product is warranted against defects in materials and workmanship for a period of two (2) years from the date of shipment to Buyer.

The Warranty is limited to repair or replacement of the defective unit at the option of the manufacturer. This warranty is void if the product has been altered, misused, dismantled, or otherwise abused.

ALL OTHER WARRANTIES, EXPRESSED OR IMPLIED, ARE EXCLUDED, INCLUDING BUT NOT LIMITED TO THE IMPLIED WARRANTIES OF MERCHANTABILITY AND FITNESS FOR A PARTICULAR PURPOSE.