

Flow Computer

Installation and Operating Instructions

WARRANTY

Kessler-Ellis Products Company warrants its products against defects in material and workmanship for a period of two (2) years from the date of shipment to the Buyer.

The Warranty is limited to repair or replacement of the defective unit at the option of KEP. This Warranty is void if the product has been altered, misused, dismantled, or otherwise abused.

ALL OTHER WARRANTIES, EXPRESSED OR IMPLIED, ARE EXCLUDED, INCLUDING BUT NOT LIMITED TO THE IMPLIED WARRANTIES OF MERCHANTABILITY AND FITNESS FOR A PARTICULAR PURPOSE.

We hope you will be pleased with our products. If you have any questions concerning our Warranty, repair, modification or return goods process, please contact your local KEP distributor or the KEP Customer Service Department at 1-800-631-2165.

Kessler-Ellis Products Co.
10 Industrial Way East
Eatontown, NJ 07724
Phone: (732) 935-1320
Toll Free 1-800-631-2165
Fax: (732) 935-9344

PROPRIETARY NOTICE

The information contained in this publication is derived in part from proprietary and patent data of the Kessler-Ellis Products Company. This information has been prepared for the expressed purpose of assisting operating and maintenance personnel in the efficient use of the instrument described herein. Publication of this information does not convey any rights to use or reproduce it or to use for any purpose other than in connection with the installation, operation and maintenance of the equipment described herein.

Fourth Edition
99245 REV 6/16/97
Copyright 1987, 1988
Printed in USA. All Rights Reserved.

ORDERING GUIDE

EXAMPLE:

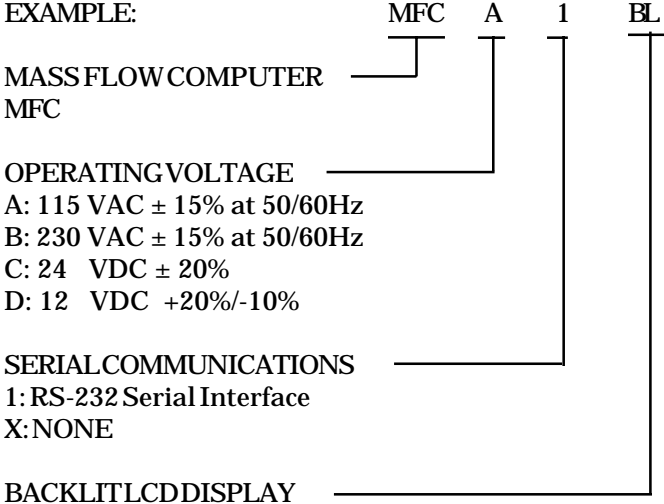

ACCESSORIES

- NEMATROL4X1 NEMA4 enclosure for wall mounting with cutout for one TROL unit
- NEMATROL4X2 NEMA4 enclosure for wall mounting with cutout for two TROL unit

Appendix iv

Alarm Messages

Note: All Alarm messages are followed by the phrase:
"Press ENT to quiet".

This will clear the alarm relay. It does not correct alarm conditions. If the alarm condition is still present, the alarm relay will pull in again.

Messages

PRESS TOO LOW: Gauge pressure has gone below the Lo alarm value set in the variables.

PRESS TOO HI: Gauge pressure has gone above the Hi alarm value set in the variables.

TEMP TOO LOW: Temperature has gone below the Lo alarm value set in the variables or has improper or broken RTD hookup.

TEMP TOO HI: Temperature has gone above the Hi alarm value set in the variables.

Insufficient flow: Compensated flow has gone below the Lo alarm value set in the variables.

Excessive flow: Compensated flow has gone above the Hi alarm value set in the variables.

Analog out error: 4-20 mA output loop is broken or Compensated flow has exceeded the 20 mA value set in variables.

4-20mA loop broken: One of the 4-20 mA input loops is broken.

Off steam tables: Temperature or pressure inputs have gone below or exceeded the range of the Flow Computer's internal steam tables.

Wet steam condition: Typically a delayed alarm. Alarm occurs if condition persists for longer than two minutes. Temperature or pressure inputs have gone below the saturated steam range of the Flow Computer's internal steam tables.

WARNING !

This instrument contains electronic components that are susceptible to damage by static electricity. Please observe the following handling procedures during the removal, installation, or handling of internal circuit boards or devices.

Handling Procedures

1. Power to unit must be removed.
2. Personnel must be grounded, via wrist strap or other safe, suitable means, before any printed circuit board or other internal device is installed, removed or adjusted.
3. Printed circuit boards must be transported in a conductive bag or other conductive container. Boards must not be removed from protective enclosure until the immediate time of installation. Removed boards must be placed immediately in protective container for transport, storage, or return to factory.

Comments

This instrument is not unique in its content of EDS (electrostatic discharge) sensitive components. Most modern electronic designs contain components that utilize metal oxide technology (NMOS, CMOS, etc.). Experience has proven that even small amounts of static electricity can damage or destroy these devices. Damaged components, even though they appear to function properly, exhibit early failure.

Manual 99245
REV 6/16/97

TABLE OF CONTENTS

CHAPTERS	PAGE NUMBER
1.0 Introduction	
1.1 Description of the Flow Computer	1-1
1.2 Flow Computer Features	1-2
1.3 Flow Computer Application	1-3
2.0 Installation of the Flow Computer	
2.1 Mounting the Flow Computer	2-1
2.2 Connecting Inputs and Outputs	2-1
Dimensional Layout	2-2
Wiring Label	2-3
RTD Wiring Diagrams	2-4
Analog Input Wiring Diagrams	2-5
Analog Output Wiring Diagram	2-6
Pulse Input and Output Wiring Diagrams	2-7
3.0 Programming Considerations	
3.1 Programming	3-1
3.2 Front Panel Keypad Operation	3-1
3.3 Programming the Flow Computer	3-2
3.4 Top Level Setup Menu	3-4
3.5 Setting the Computations	3-4
3.6 Setting the Engineering Units	3-6
3.7 Setting the Hardware	3-7
3.8 Setting the Variables	3-9
3.9 Clearing the Totalizer	3-22
3.10 Checking the Alarm	3-23
3.11 Locking and Unlocking the Flow Computer	3-24
3.12 Setting the Real Time Clock	3-26
3.13 Setting the Serial Interface	3-28
3.14 Crossing Over From Setup to Running Mode ..	3-31
3.15 Showing Data	3-32
3.16 Setting up the Data Display	3-32
3.17 Setting up the Print List	3-35
3.18 Print System Setup	3-36

Appendix iii

Programming Error Messages

Note: All Error messages are followed by the phrase:
"Push ENT to continue".

These messages occur when attempting to go to the running mode without entering necessary information or entering a value that is not allowed.

Messages

Temp hi-lo lim err: Temperature input parameters have not been entered or a low limit is higher than a high limit.

Press hi-lo lim err: Pressure input parameters have not been entered or a low limit is higher than a high limit.

Flow hi-lo lim err: Flow input parameters have not been entered or a low limit is higher than a high limit.

Need more flow info: All of the Flow input parameters have not been entered.

Z factor error: Z factor has been set to zero, change to any number greater than zero.

Scale factor error: K factor has been set to zero, change to any number greater than zero.

No value stored yet: The unit still has the null value in it from initialization. Enter a value.

Bad lock code: Attempt has been made to enter 00000 as the lock-out code, use any other number than 00000 to lock out computer.

Syntax error: Time or date was not entered in proper format. Refer to Section 3.12 for proper format.

Bad Time value: Invalid time entered. Refer to Section 3.12 for proper format.

Bad Date value: Invalid date entered. Refer to Section 3.12 for proper format.

Bad ID value: Invalid ID entered. Refer to Section 3.13 for proper format.

CONVERSION TABLE:

Convert From:

ENGLISH x (CONVERSION FACTOR) = METRIC

ft ³ /min	x	1.69902	=	m ³ /h
GPM	x	0.063085	=	liters/sec
lbm/h	x	0.45359	=	kg/h
Btu/h	x	0.0002928	=	kW
Btu/h	x	0.252	=	kcal/h
Btu/h	x	0.001055056	=	MJ/h
ft ³	x	0.028317	=	m ³
gals	x	3.785109	=	liters
lbm	x	0.45359	=	kg
Btu	x	0.0002928	=	kWh
Btu	x	0.252	=	kcal
Btu	x	0.001055056	=	MJ
Deg F	x	(0.555555) + (-17.7776)	=	Deg C
PSIG	x	(6.894757)	=	kPa
PSIG	x	(0.070306)	=	kg/cm ²
PSIG	x	(0.06894757)	=	bar
GPM	x	0.1337	=	ACFM
ACFM	x	7.4805	=	GPM

CHAPTERS

PAGE NUMBER

3.19 Examining Hardware	3-36
3.20 Examining Computations	3-37
3.21 Examining Variables	3-37

4.0 16 Point Programming

4.1 General Information	4-1
4.2 16 Point Digital Setup	4-2
4.3 16 Point Analog Setup	4-4
4.4 16 Point Calculations	4-6

5.0 General Specifications

5.1 Input Specifications	5-1
5.2 Output Specifications	5-1
5.3 RS232 Communications Port	5-4
5.4 Data Display and Keypad	5-6
5.5 Case Dimensions	5-7

6.0 Principles of Operation

6.1 General	6-1
6.2 Temperature Calculations	6-1
6.3 Pressure Calculations	6-1
6.4 Flow Calculations	6-2
6.5 K1 Factor Calculation	6-4
6.6 C Factor Calculation	6-6

7.0 Trouble Shooting Guide

7.1 Operator Forgets Lock-out code	7-1
7.2 Pulse Inputs Not Counting	7-2
7.3 Reinitializing Instrument	7-2

TABLE OF CONTENTS

CHAPTERS PAGE NUMBER

8.0 RS232 Serial Communications
 Table of Chapter Contents 8-1

Appendix i Operating Parameters

Appendix ii Conversion Factors

Appendix iii Programming Error Messages

Appendix iv Alarm Messages

Flow Input Parameters - Heat-Liquid

<u>Parameter</u>	<u>Default</u>	<u>English</u>	<u>Metric (KPa)</u>	<u>Metric (Kg/cm2)</u>	<u>Metric (bars)</u>	<u>Notes</u>
K factor	null	Pulses/gal.	Pulses/liter	Pulses/liter	Pulses/liter	digital
Input filter	40000.0	Hertz	Hertz	Hertz	Hertz	digital
K1 Factor	null	As Needed	As Needed	As Needed	As Needed	orifice/pitot
Delta P Lo	null	In of Water	mm of Water	mm of Water	mm of Water	orifice/pitot
Delta P Hi	null	In of Water	mm of Water	mm of Water	mm of Water	orifice/pitot
Low flow	null	GPM	LPS	LPS	LPS	analog
Hi Flow	null	GPM	LPS	LPS	LPS	analog
Lo Cutoff	0.0	GPM	LPS	LPS	LPS	analog, orifice/pitot
Specific Gravity	null	Dimensionless				
C Factor (x10 ⁻⁶)	null	Coefficient of Expansion				
Mean Spec. Heat	null	BTU/lb-°F	Whr/Kg-°C	Kcal/Kg-°C	MJ/Kg-°C	
Low alarm	0.0	BTU/min	KWhr/min	Kcal/min	MJ/min	
Hi alarm	99999	BTU/min	KWhr/min	Kcal/min	MJ/min	
Min flow out	null	BTU/min	KWhr/min	Kcal/min	MJ/min	
Max flow out	null	BTU/min	KWhr/min	Kcal/min	MJ/min	
Pulse Out Scaling	null	Pulses/BTU	Pulses /Whr	Pulses /Kcal	Pulses /KJ	

Flow Input Parameters - Del Heat-Liquid

<u>Parameter</u>	<u>Default</u>	<u>English</u>	<u>Metric (KPa)</u>	<u>Metric (Kg/cm2)</u>	<u>Metric (bars)</u>	<u>Notes</u>
K factor	null	Pulses/gal.	Pulses/liter	Pulses/liter	Pulses/liter	digital
Input filter	40000.0	Hertz	Hertz	Hertz	Hertz	digital
K1 Factor	null	As Needed	As Needed	As Needed	As Needed	orifice/pitot
Delta P Lo	null	In of Water	mm of Water	mm of Water	mm of Water	orifice/pitot
Delta P Hi	null	In of Water	mm of Water	mm of Water	mm of Water	orifice/pitot
Low flow	null	GPM	LPS	LPS	LPS	analog
Hi Flow	null	GPM	LPS	LPS	LPS	analog
Lo Cutoff	0.0	GPM	LPS	LPS	LPS	analog, orifice/pitot
Specific Gravity	null	Dimensionless				
C Factor (x10 ⁻⁶)	null	Coefficient of Expansion				
Mean Spec. Heat	null	BTU/lb-°F	Whr/Kg-°C	Kcal/Kg-°C	MJ/Kg-°C	
Low alarm	0.0	BTU/min	KWhr/min	Kcal/min	MJ/min	
Hi alarm	99999	BTU/min	KWhr/min	Kcal/min	MJ/min	
Min flow out	null	BTU/min	KWhr/min	Kcal/min	MJ/min	
Max flow out	null	BTU/min	KWhr/min	Kcal/min	MJ/min	
Pulse Out Scaling	null	Pulses /BTU	Pulses /Whr	Pulses /Kcal	Pulses /KJ	

Operating Parameters

Flow Input Parameters - Heat-Gas

Parameter	Default	English	Metric (KPa)	Metric (Kg/cm2)	Metric (bars)	Notes
K factor	null	Pulses/ft ³ .	Pulses/M ³	Pulses/M ³	Pulses/M ³	digital
Input filter	40000.0	Hertz	Hertz	Hertz	Hertz	digital
K1 Factor	null	As Needed	As Needed	As Needed	As Needed	orifice/pitot
Delta P Lo	null	In of Water	mm of Water	mm of Water	mm of Water	orifice/pitot
Delta P Hi	null	In of Water	mm of Water	mm of Water	mm of Water	orifice/pitot
Low flow	null	ACFM	M ³ /hr	M ³ /hr	M ³ /hr	analog
Hi Flow	null	ACFM	M ³ /hr	M ³ /hr	M ³ /hr	analog
Lo Cutoff	0.0	ACFM	M ³ /hr	M ³ /hr	M ³ /hr	analog, orifice/pitot
Z factor	null	Gas compressibility				
Specific Gravity	null	Dimensionless				
Mean Specific Heat	null	BTU/lb-°F		Whr/Kg-°C	Kcal/Kg-°C	MJ/Kg-°C
Low alarm	0.0	BTU/min	KWhr/min	Kcal/min	MJ/min	
Hi alarm	99999	BTU/min	KWhr/min	Kcal/min	MJ/min	
Min flow out	null	BTU/min	KWhr/min	Kcal/min	MJ/min	
Max flow out	null	BTU/min	KWhr/min	Kcal/min	MJ/min	
Pulse Out Scaling	null	Pulses /BTU	Pulses /Whr	Pulses /Kcal	Pulses /KJ	

Flow Input Parameters - Heat-Steam

Parameter	Default	English	Metric (KPa)	Metric (Kg/cm2)	Metric (bars)	Notes
K factor	null	Pulses/ft ³ .	Pulses/M ³	Pulses/M ³	Pulses/M ³	digital
Input filter	40000.0	Hertz	Hertz	Hertz	Hertz	digital
K1 Factor	null	As Needed	As Needed	As Needed	As Needed	orifice/pitot
Delta P Lo	null	In of Water	mm of Water	mm of Water	mm of Water	orifice/pitot
Delta P Hi	null	In of Water	mm of Water	mm of Water	mm of Water	orifice/pitot
Low flow	null	ACFM	M ³ /hr	M ³ /hr	M ³ /hr	analog
Hi Flow	null	ACFM	M ³ /hr	M ³ /hr	M ³ /hr	analog
Lo Cutoff	0.0	ACFM	M ³ /hr	M ³ /hr	M ³ /hr	analog, orifice/pitot
Low alarm	0.0	BTU/min	KWhr/min	Kcal/min	MJ/min	
Hi alarm	99999	BTU/min	KWhr/min	Kcal/min	MJ/min	
Min flow out	null	BTU/min	KWhr/min	Kcal/min	MJ/min	
Max flow out	null	BTU/min	KWhr/min	Kcal/min	MJ/min	
Pulse Out Scaling	null	Pulses /BTU	Pulses /Whr	Pulses /Kcal	Pulses /KJ	

Chapter 1

1.0 Introduction

1.1 Description of the Flow Computer

The Flow Computer is a microprocessor based instrument designed to measure and compensate flow in an industrial environment. Three inputs, temperature, pressure and flow, are provided for calculating the flow at standard conditions. Special signal conditioning circuitry is included to allow direct connection of 2, 3 or 4 wire platinum Resistance Temperature Detectors (RTD's), voltage inputs or current loops. A high speed digital input is provided for pulsing types of flowmeters. A 32 terminal strip on the rear panel provides easy connection to the instrument.

The Flow Computer is powered by 50 or 60 Hz, 110 or 220 VAC, switch selectable, or can be ordered for 12 or 24 VDC power.

The Flow Computer is designed to provide continuous, on-line, compensation for true flow rate from volumetric flow transducers. All volumetric, mass or heat flow calculations are taken with permission from the Flow Measurement Engineering Handbook written by R. W. Miller. Steam (100% quality, saturated or superheated to 900°F) computations are based on the 1967 ASME Steam tables.

Operator interface is through a 16 key keypad and a 2 line by 20 character liquid crystal display. (The Flow Computer may also be set up entirely through the optional RS232 port.) Range selection, input filtering characteristics, scaling factors, etc. are selected through the front panel keypad or RS232 interface. There is no need to disassemble the unit or set any dip switches.

Scaled digital and 4-20 mA analog current outputs, that represent compensated flow, are standard for use in remote monitoring of flow. Two form C relays provide isolated compensated flow and temperature/pressure alarm outputs.

There is a single precision voltage reference in the unit used for all analog measurements. A single multi-turn potentiometer is provided for factory calibration. No other adjustments are necessary.

1.2 Flow Computer Features

The Flow Computer is designed to provide accurate and low cost compensated flow measurement for industrial applications. The instrument can be set up to display volumetric, mass, or heat flow, as well as totalized flow, with an overall accuracy of 0.25% over commonly required application ranges.

Fully programmable from the front keypad, the microprocessor-based Flow Computer provides the operator with prompts to set up the operating parameters of the instrument.

The Flow Computer offers the following features:

- Front panel 16 key programming keypad
- 2 line by 20 character backlit LCD display
- Compensates gas, steam & liquid flow rates for temperature and pressure.
- Direct input of 100 Ω RTD
- Can display flow and heat flow rates and totals
- 12 bit input resolution for A/D conversion
- Non-volatile RAM memory
- Self diagnostics of instrument
- RS232 communications (optional)
- Supervisory lockout of keypad
- Provides 24 VDC output @ 100mA (AC Models only)
- Flow rate, temperature and pressure alarms
- Real time clock and calendar (not battery backed)

Flow Input Parameters - Steam Mass

Parameter	Default	English	Metric (KPa)	Metric (Kg/cm2)	Metric (bars)	Notes
K factor	null	Pulses/ft ³	Pulses/M ³	Pulses/M ³	Pulses/M ³	digital
Input filter	40000.0	Hertz	Hertz	Hertz	Hertz	digital
K1 Factor	null	As Needed	As Needed	As Needed	As Needed	orifice/pitot
Delta P Lo	null	In of Water	mm of Water	mm of Water	mm of Water	orifice/pitot
Delta P Hi	null	In of Water	mm of Water	mm of Water	mm of Water	orifice/pitot
Low flow	null	ACFM	M ³ /hr	M ³ /hr	M ³ /hr	analog
Hi Flow	null	ACFM	M ³ /hr	M ³ /hr	M ³ /hr	analog
Lo Cutoff	0.0	ACFM	M ³ /hr	M ³ /hr	M ³ /hr	analog, orifice/pitot
Low alarm	0.0	lb/min	Kg/min	Kg/min	Kg/min	
Hi alarm	99999	lb/min	Kg/min	Kg/min	Kg/min	
Min flow out	null	lb/min	Kg/min	Kg/min	Kg/min	
Max flow out	null	lb/min	Kg/min	Kg/min	Kg/min	
Pulse Out Scaling	null	Pulses per lb	Pulses per Kg	Pulses per Kg	Pulses per Kg	

Flow Input Parameters - Liquid Mass

Parameter	Default	English	Metric (KPa)	Metric (Kg/cm2)	Metric (bars)	Notes
K factor	null	Pulses/gal.	Pulses/liter	Pulses/liter	Pulses/liter	digital
Input filter	40000.0	Hertz	Hertz	Hertz	Hertz	digital
K1 Factor	null	As Needed	As Needed	As Needed	As Needed	orifice/pitot
Delta P Lo	null	In of Water	mm of Water	mm of Water	mm of Water	orifice/pitot
Delta P Hi	null	In of Water	mm of Water	mm of Water	mm of Water	orifice/pitot
Low flow	null	GPM	LPS	LPS	LPS	analog
Hi Flow	null	GPM	LPS	LPS	LPS	analog
Lo Cutoff	0.0	GPM	LPS	LPS	LPS	analog, orifice/pitot
Specific Gravity	null	Dimensionless				
C Factor (x10-6)	null	Coefficient of Expansion				
Low alarm	0.0	lbm/min	Kg/min	Kg/min	Kg/min	
Hi alarm	99999	lbm/min	Kg/min	Kg/min	Kg/min	
Min flow out	null	lbm/min	Kg/min	Kg/min	Kg/min	
Max flow out	null	lbm/min	Kg/min	Kg/min	Kg/min	
Pulse Out Scaling	null	Pulses /lbm	Pulses /Kg	Pulses /Kg	Pulses /Kg	

Flow Input Parameters - Liquid Volume

Parameter	Default	English	Metric (KPa)	Metric (Kg/cm2)	Metric (bars)	Notes
K factor	null	Pulses/gal.	Pulses/liter	Pulses/liter	Pulses/liter	digital
Input filter	40000.0	Hertz	Hertz	Hertz	Hertz	digital
K1 Factor	null	As Needed	As Needed	As Needed	As Needed	orifice/pitot
Delta P Lo	null	In of Water	mm of Water	mm of Water	mm of Water	orifice/pitot
Delta P Hi	null	In of Water	mm of Water	mm of Water	mm of Water	orifice/pitot
Low flow	null	GPM	LPS	LPS	LPS	analog
Hi Flow	null	GPM	LPS	LPS	LPS	analog
Lo Cutoff	0.0	GPM	LPS	LPS	LPS	analog, orifice/pitot
Specific Gravity	null	Dimensionless				
C Factor (x10-6)	null	Coefficient of Expansion				
Low alarm	0.0	GPM	LPM	LPM	LPM	
Hi alarm	99999	GPM	LPM	LPM	LPM	
Min flow out	null	GPM	LPM	LPM	LPM	
Max flow out	null	GPM	LPM	LPM	LPM	
Pulse Out Scaling	null	Pulses /gal	Pulses /lit	Pulses /lit	Pulses /lit	

Operating Parameters

Pressure Input Parameters

Parameter	Default	English	Metric (KPa)	Metric (Kg/cm ²)	Metric (bars)	Notes
Low Pressure	0.0	PSIG	KPa	Kg/cm ²	bar	All
High Pressure	0.0	PSIG	KPa	Kg/cm ²	bar	All
Bar. Pressure	14.696	PSIA	KPa	Kg/cm ²	bar	All
Low alarm	0.0	PSIG	KPa	Kg/cm ²	bar	All
Hi alarm	25000	PSIG	KPa	Kg/cm ²	bar	All

Temperature Input Parameters

Parameter	Default	English	Metric (KPa)	Metric (Kg/cm ²)	Metric (bars)	Notes
Low Temp	null	Degrees F	Degrees C	Degrees C	Degrees C	All but RTD
High Temp	null	Degrees F	Degrees C	Degrees C	Degrees C	All but RTD
Base Ref. Temp	60.0	Degrees F	Degrees C	Degrees C	Degrees C	Liquid, Temp1 only
Low alarm	0.0	Degrees F	Degrees C	Degrees C	Degrees C	All
Hi alarm	850.0	Degrees F	Degrees C	Degrees C	Degrees C	All

Flow Input Parameters - Ideal Gas Volume

Parameter	Default	English	Metric (KPa)	Metric (Kg/cm ²)	Metric (bars)	Notes
K factor	null	Pulses/ft ³	Pulses/M ³	Pulses/M ³	Pulses/M ³	digital
Input filter	40000.0	Hertz	Hertz	Hertz	Hertz	digital
K1 Factor	null	As Needed	As Needed	As Needed	As Needed	orifice/pitot
Delta P Lo	null	In of Water	mm of Water	mm of Water	mm of Water	orifice/pitot
Delta P Hi	null	In of Water	mm of Water	mm of Water	mm of Water	orifice/pitot
Low flow	null	ACFM	M ³ /hr	M ³ /hr	M ³ /hr	analog
Hi Flow	null	ACFM	M ³ /hr	M ³ /hr	M ³ /hr	analog
Lo Cutoff	0.0	ACFM	M ³ /hr	M ³ /hr	M ³ /hr	analog, orifice/pitot

Z factor	null	Gas compressibility				
Specific Gravity	null	Dimensionless				
Low alarm	0.0	SCFM	NM ³ /min	NM ³ /min	NM ³ /min	
Hi alarm	99999	SCFM	NM ³ /min	NM ³ /min	NM ³ /min	
Min flow out	null	SCFM	NM ³ /min	NM ³ /min	NM ³ /min	
Max flow out	null	SCFM	NM ³ /min	NM ³ /min	NM ³ /min	
Pulse Out Scaling	null	Pulses /SCF	Pulses /M ³	Pulses /M ³	Pulses /M ³	

Flow Input Parameters - Ideal Gas Mass

Parameter	Default	English	Metric (KPa)	Metric (Kg/cm ²)	Metric (bars)	Notes
K factor	null	Pulses/ft ³	Pulses/M ³	Pulses/M ³	Pulses/M ³	digital
Input filter	40000.0	Hertz	Hertz	Hertz	Hertz	digital
K1 Factor	null	As Needed	As Needed	As Needed	As Needed	orifice/pitot
Delta P Lo	null	In of Water	mm of Water	mm of Water	mm of Water	orifice/pitot
Delta P Hi	null	In of Water	mm of Water	mm of Water	mm of Water	orifice/pitot
Low flow	null	ACFM	M ³ /hr	M ³ /hr	M ³ /hr	analog
Hi Flow	null	ACFM	M ³ /hr	M ³ /hr	M ³ /hr	analog
Lo Cutoff	0.0	ACFM	M ³ /hr	M ³ /hr	M ³ /hr	analog, orifice/pitot

Z factor	null	Gas compressibility				
Specific Gravity	null	Dimensionless				
Low alarm	0.0	lb/min	Kg/min	Kg/min	Kg/min	
Hi alarm	99999	lb/min	Kg/min	Kg/min	Kg/min	
Min flow out	null	lb/min	Kg/min	Kg/min	Kg/min	
Max flow out	null	lb/min	Kg/min	Kg/min	Kg/min	
Pulse Out Scaling	null	Pulses per lb	Pulses per Kg	Pulses per Kg	Pulses per Kg	

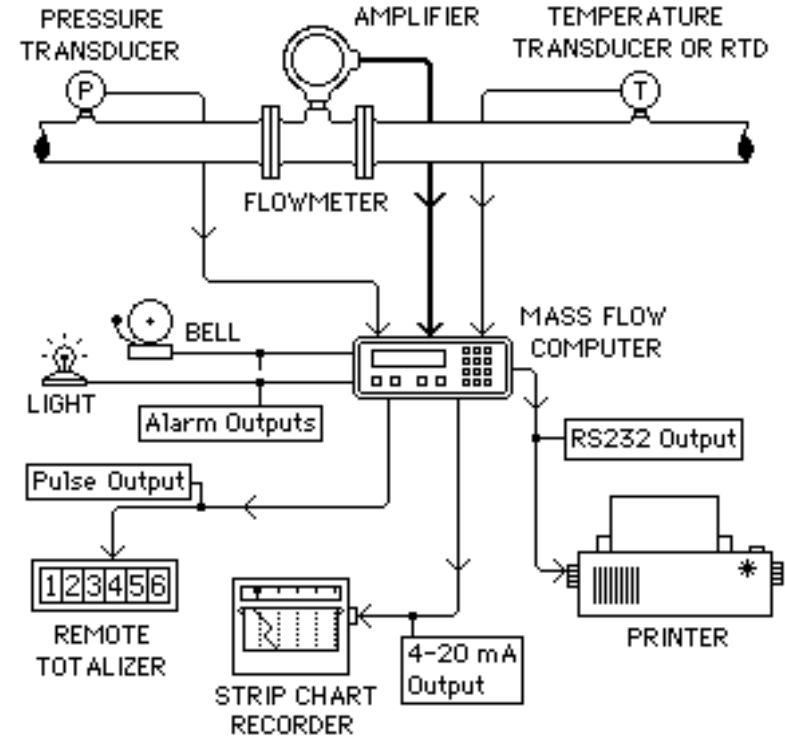

1.3 Flow Computer Application

- § Pressure transducer sends 0-5V signal to Flow Computer.
- § 100 Ω RTD direct hook-up to Flow Computer.
- § Turbine flowmeter sends digital signal to Flow Computer.
- § Flow Computer calculates flow and sends out signals.
- § 5 V pulse out to remote totalizer in supervisory area.
- § 4-20 mA out to strip chart recorder tracks trends.
- § RS232 out to printer for data logging.
- § Alarm relays activate bell and/or light as needed.

Chapter 2

2.0 Installation of the Instrument

2.1 Mounting the Instrument

The Flow Computer can be mounted in a user panel greater than 0.047" (1.2mm) and less than 0.187" (4.7mm) thick. Figure 2-1 shows the cutout dimensions, bezel size, and depth needed for the instrument. Be sure to provide additional space for cabling and connections behind the instrument (approximately 1.0"). Additionally, all wiring to the back of the instrument should have sufficient service loops to allow for the easy removal of the instrument from the panel.

Slip the gasket provided over the rear of the instrument case and slide it forward until it engages the inner surface of the front bezel. Install the screws provided in the mounting brackets and insert in the slots located on all four sides of the instrument. Tighten the screws to firmly secure the bezel and gasket up against the panel.

CAUTION: do not over tighten mounting brackets.

2.2 Connecting Inputs and Outputs

Make sure all power is disconnected before making any electrical connections. All connections are completed at the rear terminal strips as indicated in the external wiring diagram. If cables are in areas with heavy electrical fields, shielding will be required for noise immunity. One end of the shielding should be connected to earth ground. Figures 2-2 through 2-5 show the input, output, and power wiring locations for the 32 point terminal block on the back of the instrument.

CAUTION: An external fuse is recommended.
100mA Fuse for 115 VAC Powered Units.
50mA Fuse for 220 VAC Powered Units.

CAUTION: Do not short the +24 VDC output to any of the current (+I) inputs.
THIS WILL DAMAGE THE UNIT!

Example: Suppose n=9 corresponded to the displayable ANALOG OUTPUT value. The command X 9 might result in the response:

X 9 (CR)

Terminal responds: 4.00mA

EXCEPTION REPORTING

Exception Reporting is used to send out a report whenever an alarm condition is present. As soon as an alarm condition occurs, the unit sends out the following information over the RS232 lines.

The Unit I.D. Number
The Time and Date
The Alarm Condition(s)

The Unit will then send this information out, along with the print list selected, every print interval (if the print Interval is greater than 0.24999 minutes).

Every time an alarm condition is corrected, another exception report will be generated saying that the alarm condition is no longer present.

NOTE: Even though the alarm condition may have been corrected and the report sent out, the alarm relay will **not** shut off until cleared through the front keypad or the RS232 link.

continued from previous page . . .

The instrument is unlocked by supplying the same 5 digit lock code used to lock the instrument.

If the 5 digit code is unknown, use UNLOCK 00000 and the instrument will give a call in code which the factory can decode into an appropriate, one time usable, unlock code (See Section 7.1 of Operator Manual.). Then, enter UNLOCK nnnnn using the factory provided code to unlock the instrument.

Example: UNLOCK 12345 (CR)

SYSDUMP COMMAND

Function: The sysdump command is one of the most useful commands. With it, you may obtain a complete snapshot of the current configuration of the instrument including the values stored for all active variables.

Example: SYSDUMP (CR)

X COMMAND

Function: To allow a remote computer to access a specific piece of information, the X Command has been provided.

Format: X [n]

Where n designates the index of the displayable item as shown by the EXAMINE LIST command. (See page 8-15 for more information.)

continued next page . . .

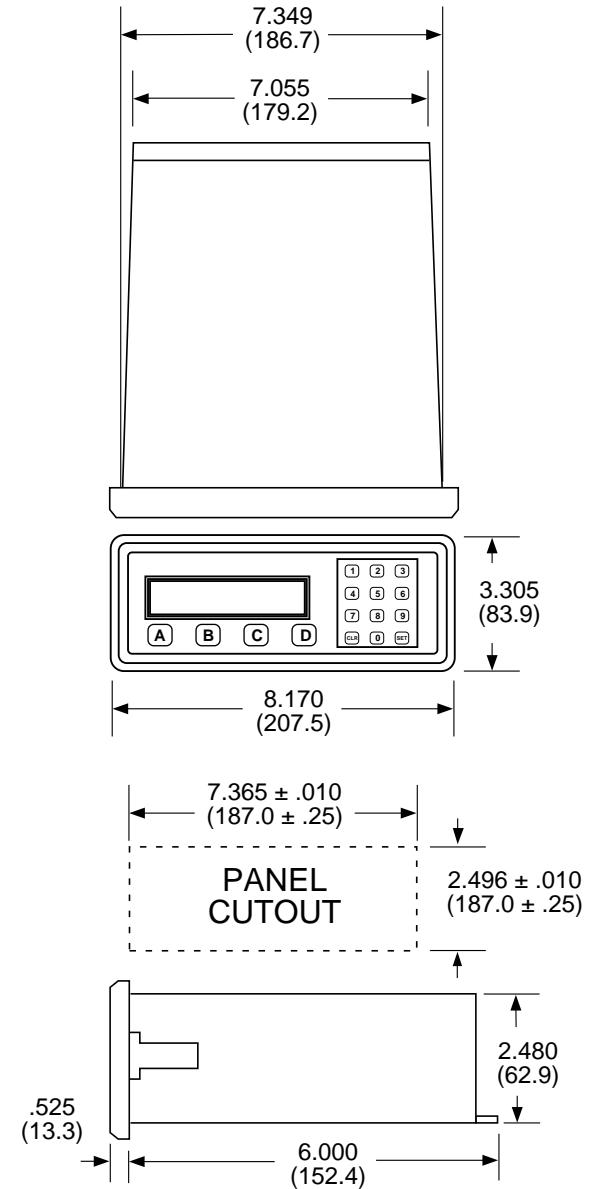

Figure 2-1
Dimensional Layout

STOP COMMAND

Reference: See Section 3.14

Function: Stops the instrument from running. Display reads: Run? Optionally "STANDBY" may be used in the same capacity.

Example: STOP (CR)

CLEAR COMMAND

Reference: See Sections 3.9 and 3.10

Function: Clears Alarms or Clears Totalizers.

This command consists of two words, the first being CLEAR and the second being either TOTALIZER or ALARM.

Example: CLEAR Totalizer (CR)

CLEAR Alarm (CR)

LOCK / UNLOCK COMMANDS

Reference: See Section 3.11

Function: Locks or unlocks the instrument.

Format: LOCK [nnnnn] (CR)

The instrument is locked by supplying a 5 digit lock code.

Example: LOCK 12345 (CR)

Format: UNLOCK [nnnnn] (CR)

continued next page . . .

PIN	HTD	WGL'NGL JN	WIRING IN	FUNCTION
1	RTD EXCITATION -	-----	-----	CHANNEL 1 TEMPERATURE
2	RTD SENSE +	-----	-----	
3	RTD SENSE -	-----	-----	
4	RTD EXCITATION -	-----	1 IN -	
5	GROUND (SHIELD) +	V IN (CH2)	1 IN (CH2)	
6	-----	V IN +	-----	
7	RTD EXCITATION -	-----	-----	CHANNEL 2 PRESSURE OR AUX TEMP
8	RTD SENSE +	-----	-----	
9	RTD SENSE -	-----	-----	
10	RTD EXCITATION -	-----	2 IN +	
11	GROUND (SHIELD) +	V IN (CH2)	2 IN (CH2)	
12	-----	V IN +	-----	
13	-----	-----	2 CH +	CHANNEL 3 F.O2 ANALOG INPUT
14	GROUND (SHIELD) +	V IN (CH2)	2 CH (CH2)	
15	-----	V IN +	-----	
16	EXCITATION VOLTAGE IS AVAILABLE TO BOTH			
17	PULSE INPUT CHANNEL:			
18	GROUND (SHIELD) +			
19	PULSE OUTPUT SIGNAL			
20	PULSE OUTPUT			
21	GROUND (SHIELD) -			
22	N.O.			ALARMS RELAY
23	N.C.			
24	COMMON			
25	N.O.			FLOW ALARM RELAY
26	N.C.			
27	COMMON			
28	1.5-230 VAC 50-60 Hz			POWER
29	1.5-230 VAC 50-60 Hz			
30	42A WIRE	24 WIRE BOND	42A WIRE TH	POWER
31	30A WIRE TO BOND	42A WIRE BOND	30A WIRE TH	

Figure 2-2
Wiring Label

EXAMINE ALARM

EXAMINEs current Alarm condition.

EXAMINE TIME

EXAMINEs real time clocks time and date.

EXAMINE DATE

EXAMINEs real time clocks time and date.

EXAMINE SERIAL

EXAMINEs the setting of the instrument for ID number, Baud Rate, and Print Interval.

EXAMINE EXCEPTION

EXAMINEs if Exception Reporting is turned ON or OFF

EXAMINE RESULTS

EXAMINEs all items on the Display List. (unit must be running)

EXAMINE LIST

EXAMINEs the list of parameters that will be printed during operations. (unit must be running)



Reference: See Section 3.14

Function: Starts the instrument running, just like the "RUN" on the main menu. Display reads: Show Data? Optionally "GO" may be used in the same capacity.

Example: RUN (CR)

Figure 2-3
RTD Wiring Diagrams

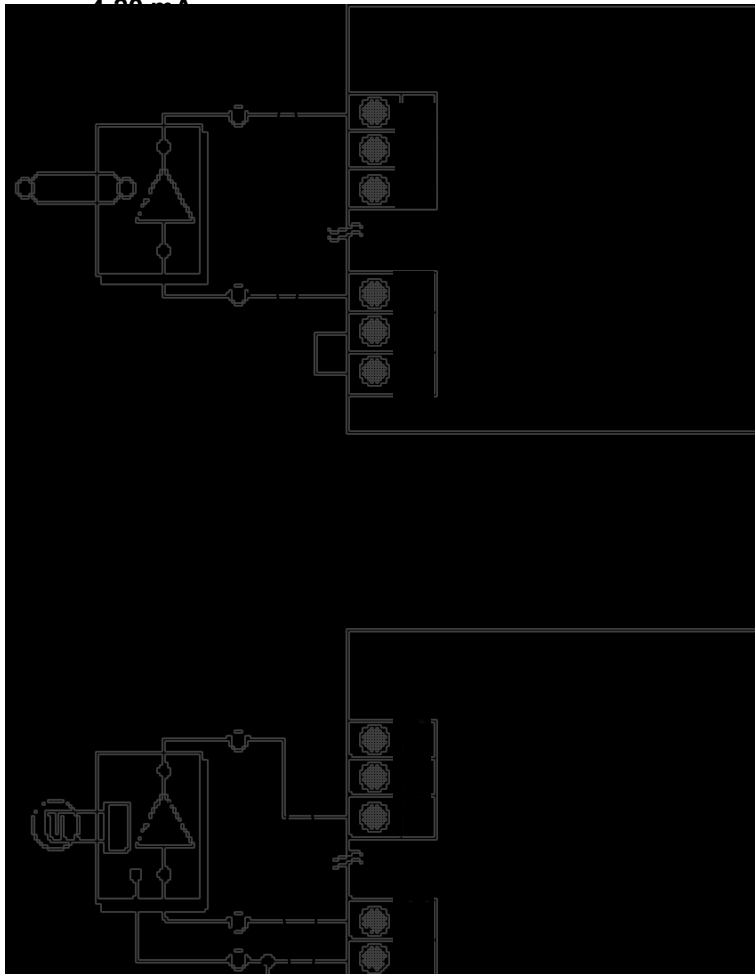

Figure 2-4
Analog Input Wiring Diagrams

REQUIRED WORDS:	OPTIONAL WORDS:
EXAMINE temperature low scale	input
EXAMINE temperature high scale	input
EXAMINE reference temperature	
EXAMINE temperature low alarm	
EXAMINE temperature high alarm	
EXAMINE temperature two low scale	input
EXAMINE temperature two high scale	input
EXAMINE temperature two low alarm	
EXAMINE temperature two high alarm	
EXAMINE pressure low scale	input
EXAMINE pressure high scale	input
EXAMINE barometric	pressure
EXAMINE pressure low alarm	
EXAMINE pressure high alarm	
EXAMINE k	factor
EXAMINE k1	factor
EXAMINE z	factor
EXAMINE gravity	specific
EXAMINE c	factor
EXAMINE specific heat	
EXAMINE point	
EXAMINE flow low scale	input
EXAMINE flow high scale	input
EXAMINE delta high	input dp
EXAMINE delta low	input dp
EXAMINE flow cutoff	low
EXAMINE flow filter	input
EXAMINE flow low alarm	
EXAMINE flow high alarm	
EXAMINE low output	flow scale
EXAMINE high output	flow scale
EXAMINE scale output	flow digital
	factor pulse

Then when the instrument is running and the PRINT INTERVAL is greater than 0.24999 minutes, the instrument will show:

```

11:55:52 Monday   January 11, 1988
Flow rate         10.000 SCFM
Totalizer         1245.000 cu-ft
Pressure          12.000 PSIG
    
```

EXAMINE COMMAND

Reference: See Section 3.19 to 3.21

Function: The EXAMINE commands are used to examine setup information about the instrument.

EXAMINE COMPUTATIONS

Examines if computations that will be used have been set for Volume, Mass or Heat for Gas, Liquid or Steam.

EXAMINE UNITS

Examines which engineering units have been set in the instrument, (English or Metric).

EXAMINE HARDWARE

Examine specific hardware settings of the instrument, and tells if instrument is locked or unlocked

SPECIFIC EXAMINE COMMANDS

In addition to the EXAMINE Commands listed previously, there are SPECIFIC EXAMINE COMMANDS that allow specific parameters to be examined remotely.

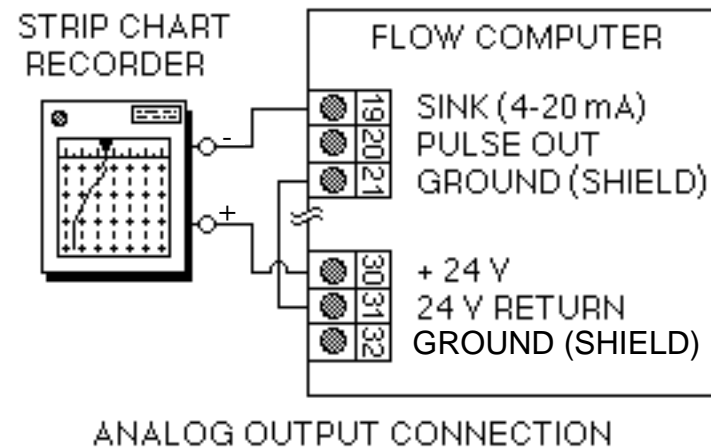

Figure 2-5
Analog Output Wiring Diagram

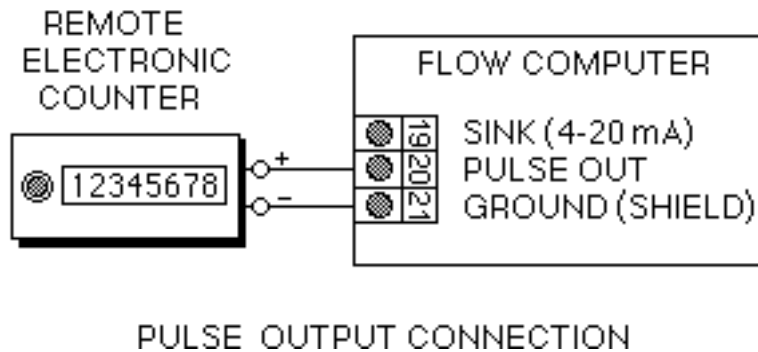
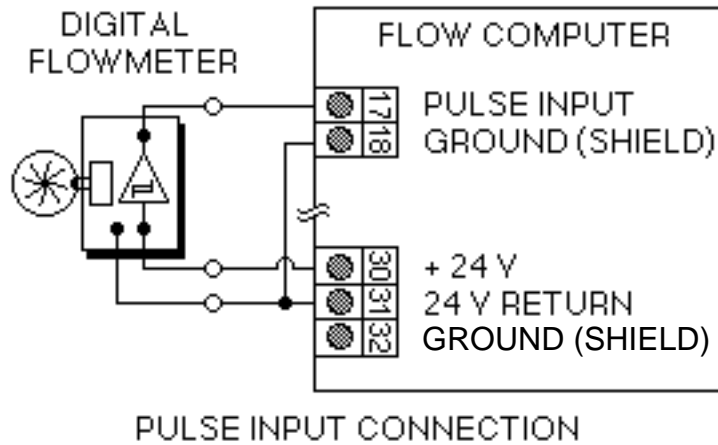

Figure 2-6
Pulse Input and Output Wiring Diagrams

SET LIST:

Reference: See Section 3.16

Format: SET LIST n n n n (CR)

Where n is the number of an item on the display list.

Function: The SET LIST command is used to set up a display list which can be periodically printed at a remote terminal or printer. The user would first type EXAMINE LIST to obtain a list of available display items, and would then use the SET LIST command to enter them into a printable list of items.

Example: MFC01>Examine list (CR)

[SELECT items from the display list:]

- [1] Time & Date
- [2] Flow rate [min]
- [3] Flow rate [hrs]
- [4] Totalizer
- [5] Temperature
- [6] Pressure
- [7] Uncompensated Flow
- [8] Raw Flow (Chan 3)
- [9] Raw Temp. (Chan 1)
- [10] Raw Press. (Chan 2)
- [11] Analog output

MFC01>

NOTE: List will vary depending on Hardware and computation selected.

Then, the user selects time, flow rate, totalizer, and pressure by typing:

MFC01>SET LIST 1 2 3 5 (CR)

SET BAUD:

Reference: See Section 3.13

Format: SET BAUD [nnnn] (CR)

Function: Sets the baud rate to the value specified in nnnn. nnnn may be 300, 1200, or 9600. The baud rate is immediately set to the value specified.

Remember: 300 Baud may cause undesirable delays in communication.

Example: SET BAUD 1200 (CR)

SET EXCEPTION:

Reference: See 8-17

Format: SET EXCEPTION [ON, OFF]

Function: Turns Exception Reporting ON or OFF.

Exception Reporting is a function that allows the operator to view different parameters that have recently gone into an alarm condition. (See section on Exception Reporting in this chapter.)

Example: SET EXCEPTION on (CR)

Chapter 3

3.0 Programming Considerations

3.1 Programming

Programming the Flow Computer for your desired operation is essentially simple. The variables required by the unit are displayed as the operator progresses through the setup menu. The unit will automatically determine its setup parameter requirements depending on the computation and hardware setup selections. To aid in the setup procedure review this chapter and fill out the worksheet as you go along.

3.2 Front Panel Keypad Operation

Programming is accomplished through the front panel with the use of the 16 keys labeled 0-9, A, B, C, D, ENT and CLR. The functions of each one is described as follows.

- A** -- Advances to the next item in the menu or sub-menu. If you are at the last item, the **A** button will have no effect on the display. The display will not wrap around to the top of the menu.
- B** -- Backs up to the previous item in the menu or sub-menu. If you are at the first item, the **B** button will have no effect on the display. The display will not wrap around to the bottom of the menu.
- C** -- Cancels current operation and goes back to the top of the menu or sub menu. No matter where you are in the menu structure, hitting cancel twice will always bring you back to Run? or Show data?
- D** -- Inserts a decimal point in the numerical value you are entering.

Just remember: **A** = Advance **C** = Cancel
 B = Back up **D** = Decimal point.

3.2 Front Panel Operation (continued)

0 - 9 - Keys used to enter in numbers. Numerical values appear from left to right as keys are pressed. Just as if you were typing. The 0 key is used to enter a negative (-) sign. Press 0 before entering the negative value.

CLR - Used as a backspace when entering numerical values. If the default value is being displayed, the **CLR** button erases the entire value.

ENT - Enters a selection or displayed value. If no value is displayed, pressing the **ENT** button will cause the default value to be displayed or an error message indicating there is no value to be displayed. Upon entry the unit will advance automatically to the next menu item.

3.3 Programming the Flow Computer

The software in the instrument contains a number of menus. This allows the setting of the various operating parameters in the instrument. You should become familiar with the function keys located on the front of the instrument before you program the Flow Computer.

Before you begin programming the Flow Computer, it will be helpful if you see an overview of how the software is structured. The software menus are used for setting up and examining the data or operating parameters. Refer to Figure 3-1 to see how the software is divided.

Note: Various selections and parameters will be explained as they are encountered in the menu.

SET ID:

Reference: See Section 4-12 in Operator Manual.

Format: SET ID (nn) (CR)

Where nn is a number from 1-99.

Function: Sets the device ID of the instrument to the number nn specified. If different from the current ID, the instrument is immediately deselected. You must type Dnn to bring it back on line.

The unit is selected using a selection code beginning with the letter D followed immediately by a one or two digit code in the range of 0-99. Further extraneous information entered on the line is ignored. The first serial command sent to it should be Dnn to bring it on line. Initially, and when the instrument is re-initialized, it defaults to Device #1. The next return character sent to the control will enable it as indicated by the MFCnn prompt, where nn indicates the device ID. When the instrument is powered up, it is deselected and must be enabled to communicate.

Note: Although there are up to 99 different ID numbers this does not mean that 99 can be driven off of one line. It is suggested that you limit the number of units to no more than 20 on a single RS232 line.

Example: SET ID 01 (CR)

SET TIME:

Reference: See Section 4-11 in Operator Manual.

Format: SET TIME [hh:mm] (CR)

Function: Sets the Real time clock in the instrument to time (hh:mm) where:

hh indicates hours (00-23)

mm indicates minutes (00-59)

NOTE: 24 hour format must be used.

Example: SET TIME 12:42 (CR)

SET DATE:

Reference: See Section 3.12

Format: SET DATE [mm/dd/yy] (CR)

Function: Sets the Real time clock in the instrument to date mm/dd/yy where:

mm indicates month (1-12)

dd indicates day (1-31)

yy indicates the year (0-99)

Year numbers 88 through 99 indicate 1988 through 1999, 00 through 87 indicate 2000 through 2087.

If desired, the year may be explicitly entered as 1988, for example.

Upon entry, the date is evaluated, and rejected if illogical (Feb 29, 1989 would be rejected, for example).

Example: SET DATE 10/2/89 (CR)

Top Level Menu Items

Figure 3-1

Press ENT to enter the selected menu subroutine.

Press C (cancel) at any time to return to the "Run?" or "Go to standby?" prompt.

Run? allows you to cross over from Setup to Run.

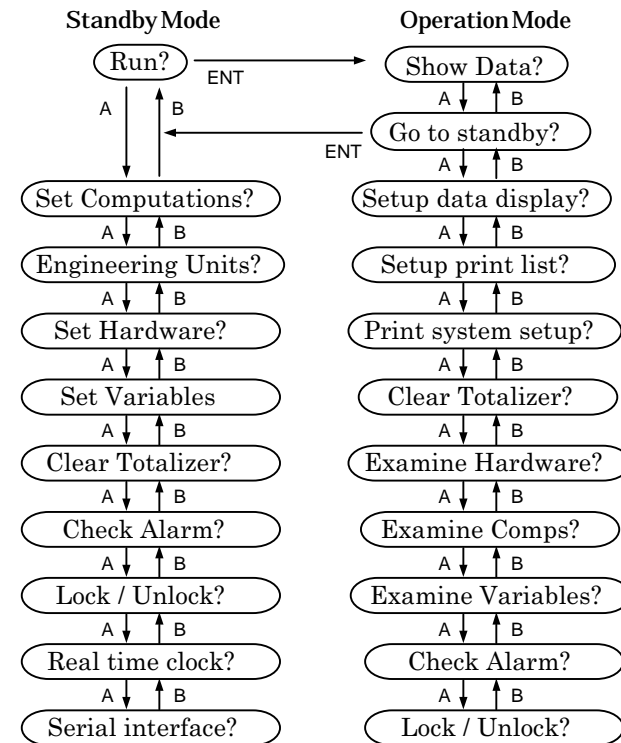
Go to standby? allows you to cross over from Run to Setup.

When in Standby mode, you can Setup and change the operating parameters of the instrument.

When in Run mode, you can Examine the operating parameters of the instrument.

In either mode you can check the alarm, clear the totalizer, or access the lock.

3.4 Top Level Setup Menu

On initial power up, the instrument will display the Top Level Setup prompts. Before entering the Run mode, you must set up the operating parameters for proper operation of the instrument. The Top Level Setup Menu is shown in Figure 3-1.

To get familiar with how the function keys work, use the **A** and **B** keys to move through the Top Level Setup Menu. Press the **C** button to jump to the top of the menu.

Under each menu there are sub-menus. The instrument will prompt you for various bits of information and decisions.

3.5 Setting the Computation

The computations are the formulas that are used by the software to process the raw data into meaningful information. Chapter 6 goes into detail about the formulas used in each computation.

To get to the Computation menu . . .

Display shows	Press
Run?	A
Set Computations?	ENT
Ideal gas - Volume?	A, B, C, or ENT

REQUIRED WORDS:	OPTIONAL WORDS:
SET pressure low scale	input
SET pressure high scale	input
SET barometric	pressure
SET pressure low alarm	
SET pressure high alarm	
SET k	factor
SET k1	factor
SET z	factor
SET gravity	specific
SET c	factor
SET specific heat	
SET point	
This command is followed by three numbers. The point number, the uncompensated flow (pulse or analog), and then the K factor.	
SET flow low scale	input
SET flow high scale	input
SET delta high	input dp
SET delta low	input dp
SET flow cutoff	low
SET flow filter	input
SET flow low alarm	
SET flow high alarm	
SET low output	flow scale
SET high output	flow scale
SET scale output	flow digital factor pulse
SET id	(See special section on SET ID; pg. 8-13)
SET baud	(See special section on SET BAUD; pg. 8-14)
SET print interval	

In addition to the optional words listed above, the words “to”, “of”, and “limit” are allowed in any phrase (in the context of the SET command) and are always ignored.

After each successfully parsed phrase, the instrument will immediately show the variable that has been changed and the new value it has been set to.

If a phrase cannot be understood or is ambiguous, the instrument will give you an error message. For example:

SET flow temperature to 12 (CR)

The instrument will not understand this command, and will give you a “Syntax Error” message. The problem with this command is that it does not understand what you want to setup, alarm or scale.

A more subtle type of problem with a command is as follows:

SET flow alarm to 100 (CR)

This phrase will also generate a “Syntax Error” because you have not fully specified the command. Specifically, it is unclear whether you mean the LOW flow alarm or the HIGH flow alarm.

Reference:

See Sections 3.8 through 3.8.5 in the Operator Manual.

REQUIRED WORDS:	OPTIONAL WORDS:
SET temperature low scale	input one
SET temperature high scale	input one
SET reference temperature	
SET temperature low alarm	one
SET temperature high alarm	one
SET temperature two low scale	input
SET temperature two high scale	input
SET temperature two low alarm	
SET temperature two high alarm	

(Continued on next page.)

Graphical representation of the Computation menu

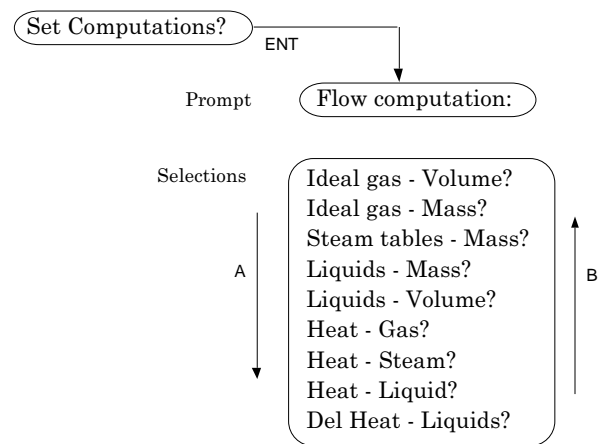

Use the following review to select the proper computation for your application.

Ideal gas - Volume: Uses volume, temperature and pressure to yield a compensated Volumetric flow. The resulting flow is displayed in SCFM (Nm³/h) and totalled in SCF (Nm³).

Ideal gas - Mass: Uses volume, temperature and pressure to yield a compensated Mass flow. The resulting flow is displayed in lbm/h (kg/h) and totalled in lbm (kg).

Steam tables - Mass: Uses volume and temperature and/or pressure to yield a compensated Mass flow. The resulting flow is displayed in lbm/h (kg/h) and totalled in lbm (kg). Unit may be set up to follow saturated steam curve, see page 3-12. (Steam tables are saturated 1 psia to 3200 psia with superheated values up to 900°F. Higher temperatures cause an alarm condition.)

Liquids - Mass: Uses volume and temperature to yield a compensated Mass flow. The resulting flow is displayed in lbm/min (kg/h) and totalled in lbm (kg).

Liquids - Volume: Uses volume and temperature to yield a compensated Volumetric flow. The resulting flow is displayed in GPM (l/s) and totalled in Gals (liters).

Heat - Gas: Uses volume, pressure and temperature to yield a compensated Mass flow as well as Heat flow. The resulting Heat flow is displayed in Btu/h (kW, kcal/h, MJ/h) and totalled in Btu (kWh, kcal, MJ).

Heat - Steam: Uses volume and pressure and/or temperature to yield a compensated Mass flow as well as Heat flow. The resulting Heat flow is displayed in Btu/h (kW, kcal/h, MJ/h) and totalled in kBtu (kWh, kcal, MJ). (Unit may be set up to follow saturated steam curve, see page 3-12)

Heat - Liquid: Uses volume and temperature to yield a compensated Mass flow as well as Heat flow. The resulting Heat flow is displayed in Btu/h (kW, kcal/h, MJ/h) and totalled in kBtu (kWh, kcal, MJ).

Del Heat - Liquids: Uses volume and two temperatures to yield a compensated Mass flow as well as Heat flow. The resulting Heat flow is displayed in Btu/h (kW, kcal/h, MJ/h) and totalled in kBtu (kWh, kcal, MJ).

3.6 Setting the Engineering Units

Engineering units establish the measuring system that is used for entry and display of the parameters. There are four selections available

To get to the Engineering menu . . .

Display shows	Press
Run?	A
Set Computations?	A
Engineering Units?	ENT
English?	A, B, C, or ENT

SPECIFIC PARAMETER SET COMMANDS

Function:

The SET command can also be used to set miscellaneous parameters in the instrument. With a SET command, a numerical argument must follow.

USING THE SET COMMAND:

If you are trying to set one of the instrument's preset variables, the instrument will parse the phrase following the word SET to find the specific preset variable you wish to access.

Certain keywords are required to uniquely identify a variable. Your phrase should be followed by a decimal number of an appropriate value.

Examples of legitimate SET phrases are as follows:

```

SET K factor 1.0123           (CR)
SET flow low input scale 0    (CR)
SET flow hi input scale 100   (CR)
SET flow low alarm 0          (CR)
SET flow hi alarm 1000.1      (CR)
SET temperature low scale input -10 (CR)
SET temperature hi scale input 100 (CR)
SET output digital scaling 10 (CR)

```

NOTE: (CR) indicates the ENTER or RETURN key of the terminal.

SET HARDWARE:

Reference: See Section 3.7

Format: SET HARDWARE [TEXT] (CR)

Function: The SET HARDWARE command parallels the Hardware Setup menu. The user may configure the input hardware using this command.

The command consists of the word SET HARDWARE, followed by the word FLOW, TEMPERATURE or PRESSURE, and then by the input characteristics desired. Key input characteristics are 5V, 10V, 4-20mA, 0-20mA, RTD, and DIGITAL. (TEMPERATURE ONE or TEMPERATURE TWO needed if Delta Heat)

Note that RTD may be used only on the temperature input(s), and DIGITAL may be used only on the FLOW input.

When configuring the flow channel, the (optional) final word is used to indicate the type of meter being used, and may be either LINEAR, SIXTEEN POINT or ORIFICE/PITOT, as required. If this qualifier is omitted, the type is not changed.

EXAMPLES:

SET HARDWARE Pressure 10V (CR)

SET HARDWARE Temperature 4-20mA (CR)

SET HARDWARE Flow Digital (CR)

SET HARDWARE Flow 4-20 Orifice (CR)

SET HARDWARE Temperature Two RTD (CR)

Graphical representation of the Engineering units menu

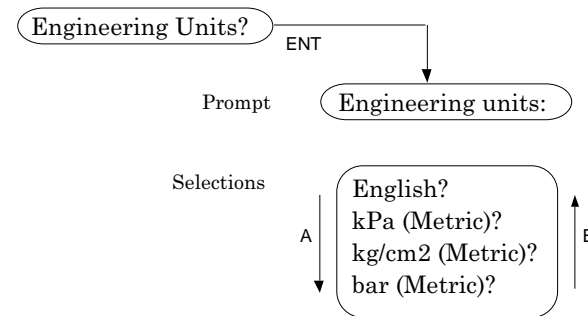

Use the following review to select the desired units for your application.

English (Imperial): Temperature °F; Pressure PSI; Other data as described in Appendix i.

kPa (Metric): Temperature °C; Pressure kPa; Other data as described in Appendix i.

kg/cm2 (Metric): Temperature °C; Pressure kg/cm2; Other data as described in Appendix i.

bar (Metric): Temperature °C; Pressure bar; Other data as described in Appendix i.

3.7 Setting the Hardware

The hardware selection determines from which input terminals the unit will get its raw data. There are no dip switches or cards to change to go from one type of input to another. Internal analog switches activate the proper terminals for the input type selected. Review the specification sheets for each type of input device to determine your needs.

To get to the Hardware menu . . .

Display shows	Press
Run?	A
Set Computations?	A until . . .
Set Hardware?	ENT
Pressure?	A, B, C, or ENT

Graphical representation of the Hardware menu

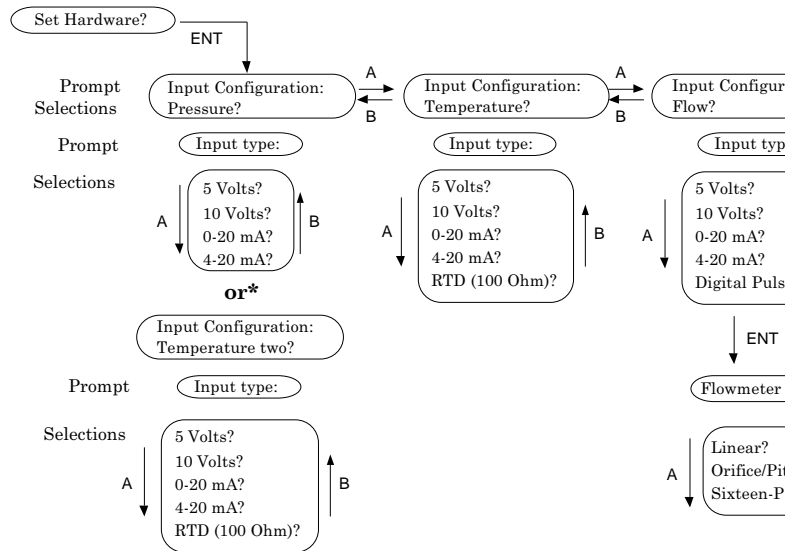

*Channel 2 may be a pressure or temperature input depending on which computation is selected.

** The flowmeter type sub-menu directly follows the Flow input type.

SET COMPUTATIONS:

Reference: See Section 3.5

Format: SET COMPUTATIONS [text] (CR)

Function: Computation units set depending on text string:

REQUIRED TEXT

VOLUME	(Ideal Gas - Volume)
MASS	(Ideal Gas - Mass)
STEAM	(Steam Tables - Mass)
LIQMASS	(Liquids - Mass)
LIQVOL	(Liquids - Volume)
HEATGAS	(Heat - Gas)
HEATSTEAM	(Heat - Steam)
HEATLIQUID	(Heat - Liquid)
DELTAHEAT	(Delta Heat - Liquid)

Example: SET COMPUTATIONS HEATSTEAM (CR)

SET UNITS:

Reference: See Section 3.6

Format: SET UNITS [text] (CR)

Function: Sets the engineering units to ENGLISH, KPA, KGCM, or BAR (depending on the text string).

Example: SET Units KPA (CR)

SET COMMAND:

SET COMMANDS allow functions to be set remotely.

SET COMMANDS:

SET COMPUTATIONS - Sets the computations that will be used for Volume, Mass or Heat Flow.

SET UNITS - Sets engineering units of the instrument to English or Metric.

SET HARDWARE - Sets specific hardware parameters of the instrument.

SET TIME - Sets the internal real time clock.

SET DATE - Sets the internal date of the instrument.

SET LIST - Sets up the list of calculated values that will be printed through the serial port while running.

SET EXCEPTION - Turns exception reporting ON or OFF.

You will also use the SET command to set the operating parameters of the instrument. Details on the SET command are on the following pages.

Notes on setting the Hardware.

The pressure input is always the gage pressure of the line. Differential pressure is selected under the flow input type.

Input Type " 5 Volts? " is a 0 to 5 volt signal. 1 to 5 Volt signals cannot be handled properly due to software constraints.

Input type " 10 Volts? " is a 0 to 10 volt signal.

Flowmeter types:

Linear is selected whenever the signal from the flowmeter is linear over the operating range.

Orifice/Pitot is the selection when the signal from the flowmeter represents a square law differential pressure. This type is not available when Digital Pulse is selected as the input type.

Sixteen-point is for compensating any other type of non-linear input signals that represent volumetric flow.

Be sure that input devices are wired to the proper terminals. If Hardware selection does not match wiring, the result will be erroneous readings.

3.8 Setting the Variables

The variables will determine how the input signals are interpreted. Constants and other parameters entered here are used by the software to display and output the compensated flow. This is the most important section of the menu. The parameters required by the unit for proper calculation are determined by the Computations, Engineering units and Hardware setup menus.

Refer to Appendix i for a complete listing of parameters used in this section and the units required for various flow equations and units of measure.

To get to the Variables menu . . .

Display shows	Press
Run?	A
Set Computations?	A until . . .
Set Variables?	ENT
Pressure Input?	A, B, C, or ENT

In the same manner that you set the Computations and the Hardware you will set the variables for the instrument.

Use the numeric keypad to input the desired variables for the instrument in the Variable menu. The **D** key sets the decimal point when entering a numerical value.

The example below shows how to enter the value of 256.58 PSIG.

At input = minimum

Lo press? **2** **5** **6** **D** **5** **8** **ENT**

The **D** key inserts a decimal point.

The **ENT** key enters the data into memory.

be transferring data between your terminal and the instrument. You have a choice of 300, 1200, or 9600 baud.

The second thing is to select the instrument identification (All of these are outlined in section 4.12).

On initial power up, the instrument default conditions are 9600 baud and Device No. 01.

Once these parameters have been set, you are free to communicate with the instrument using the commands described below. If these parameters have not been set up using the front keypad of the instrument, you will be unable to use the RS-232 communication option until they are set up properly.

Throughout the text there are references to the rest of the Manual. You should refer to them for additional information and clarification.

COMMAND CATEGORIES:

COMMAND KEYWORDS:	FUNCTION:
SET	Sets variables & parameters
EXAMINE	Examines variables & parameters
RUN	Start the instrument
STOP	Stop the instrument
CLEAR	Alarm or Totalizer
LOCK	Locks instrument
UNLOCK	Unlocks instrument
SYSDUMP	Show everything
"X" Command	Shows specific piece of information

More specific descriptions follow:

Parser

Because so much information must be typed to communicate with the instrument, a sophisticated parser has been included to facilitate this data entry. You will find that it is very forgiving of typing mistakes. This is because when you type in a command, the parser finds the closest match between what you have typed and the keywords stored in its memory. This method of “parsing to uniqueness” requires only enough information in the keyword to be able to distinguish it from the other keywords.

Additionally, when a phrase is required to indicate a specific variable, the order of the words contained in the phrase will not matter. Also, unnecessary words will not cause an error in phrases which may contain related but unnecessary words.

If a phrase cannot be understood or is ambiguous, the instrument will ignore the command and an error message will be displayed. If possible, the instrument will indicate problem areas to assist you in accurate data entry on the next try.

Line Editing:

Rudimentary line editing is accomplished by using the backspace key, which will erase the previous character.

Protocol:

The instrument operates at 300, 1200, or 9600 baud, with 8 bits, 1 stop bit, and no parity. The remote terminal or computer should be configured appropriately.

Getting Started:

The first thing that you should do when you are using the RS-232 option is to establish the baud rate that you will

3.8.1 Setting the Pressure Variables

The Pressure variables determine how the input signals from Channel 2 are interpreted. The pressure transmitter should be upstream from the flow measuring device. The Pressure sub-menu is the same no matter which computation or hardware selection you have previously selected.

Notes:

The pressure sub-menu is replaced by a second temperature sub-menu if the Del Heat - Liquids computation is selected. (See Setting the Temperature Variables.)

The pressure input is not required for Liquids - Mass or Volume computations. The functionality of the inputs and sub-menu remain active and can be used if desired.

Graphical representation of the Pressure sub-menu

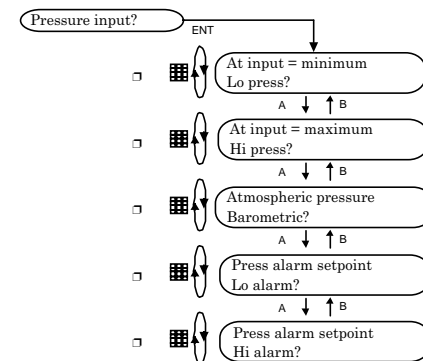

Lo press: Pressure value for the lowest analog input. (i.e. input at 4 mA = 10 PSIG)

Hi press: Pressure value for the highest analog input. (i.e. input at 20 mA = 500 PSIG)

Atmospheric pressure - Barometric: Value added to the input pressure to calculate the absolute pressure value. (i.e. 14.7 PSIA)

Lo / Hi alarms: Pressure Values programmed at which the unit activates an alarm relay.

Note: If the input signal is already compensated for the barometric pressure (i.e. signal is PSIA), set the Atmospheric pressure - Barometric to zero (0.00).

Special Note: To set the Flow Computer to follow the saturated steam curve with either: pressure and no temperature; or temperature and no pressure input; use one of these two methods.

1) Set Lo press =0.00 and Hi press =0.00.

The Flow computer will use the temperature input to look up the corresponding pressure on the saturated steam table for calculations and display.

2) Set Lo temp =0.00 and Hi temp =0.00.

The Flow computer will use the pressure input to look up the corresponding temperature on the saturated steam table for calculations and display.

3.8.2 Setting the Temperature Variables

The Temperature variables determine how the input signals from Channel 1* are interpreted. The Temperature sub-menu varies with the computation or hardware selections you have previously made.

Notes:

*The pressure sub-menu is replaced by a second temperature sub-menu if the Del Heat - Liquids computation is selected. Follow the same setup procedure as outlined in this section.

Printer Usage with the Flow Computer

The Flow Computer may be connected to a printer in order to provide data logging reports and equipment setup reports.

It is required to use a printer with a RS-232 connection. In addition, the printer must have a 2KB buffer (min.).

The printer must be compatible with the flow computers available baud rates of 300, 1200, or 9600 baud. The data format is 8 bits, 1 stop bit, and no parity.

Hardware handshaking is not supported.

The printed outputs assume a 20 column paper width.

The user can define the data logging interval and the information to be printed during the setup of the instrument.

No print strobe is supported on this model.

Line Oriented Data Input

RS-232 communication provides access to all operating parameters of the Flow Computer. The instrument constantly monitors the RS-232 port for activity, entering the data received into an internal 80 character memory buffer. Entry is terminated when a carriage return is entered (Return or Enter key) or when the buffer size is exceeded. At that time, the information is parsed by the internal parser and a dispatch to the appropriate service routine is made.

RS-232 OPERATING INSTRUCTIONS

GENERAL

This chapter summarizes operation of the MASS FLOW COMPUTER (MFC) with a remote terminal. It is recommended that you read the preceding chapters of the Operating Instructions. You should be familiar with the format and methods used in setting up the basic instrument before using the RS-232 communication option.

Setting up the RS-232 Link

The RS-232 connector is a standard 25 pin female connector (DB25S), and it is located at the rear of the instrument. Figure 8-1 shows a wiring diagram for the Sub-D 25 Pin connector. Standard inputs must present a load of 3000 to 7000 Ohms. A voltage level of +3V to +25V (reference to signal ground) is read as a "Space" or "0" and indicates an active state (asserts a control line). A voltage level of -3V to -25V is read as a "Mark" or "1" and does not indicate an active state (does not assert a control line). Outputs must send a voltage of +5V to +25V (reference to signal ground) for a "Space" and a voltage of -5V to -25V for a "Mark" when loaded with a 3000 Ohm load to signal ground. Outputs must be capable of being shorted to other signal lines without burning out. It is normally recommended that cable length be limited to 50 feet.

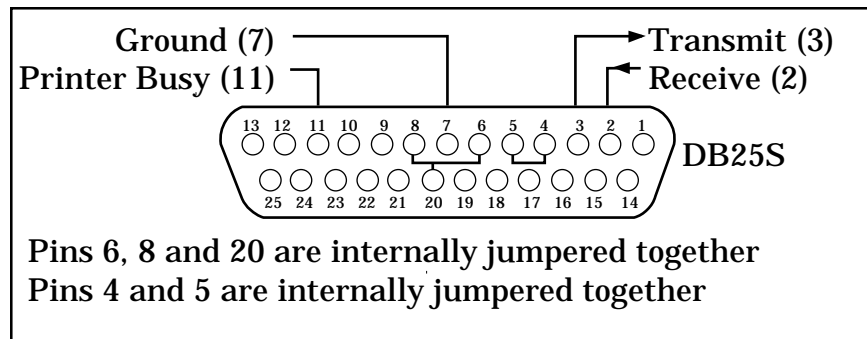
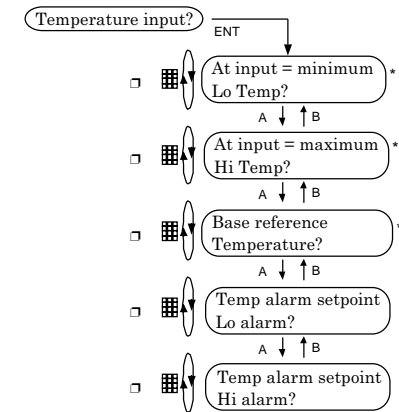

Figure 8-1

Graphical representation of the Temperature sub-menu



* These prompts do not appear if RTD (100 Ohm) is selected in hardware. The resistance is referenced to a look up table inside the Flow Computer to determine the temperature.

** This prompt appears if a liquid computation is selected (Liquids - Mass; Liquids - Volume; Heat - Liquid; Del Heat - Liquids).

ENTERING NEGATIVE VALUES

In some instances, you may want to store a negative value for the following variables: Low Temperature Scale Factor; High Temperature Scale Factor; Low Temperature Limit; High Temperature Limit

A leading minus sign may be entered by pressing the zero (0) key as the first keystroke when entering any of these values. Subsequent strokes of the zero key will result in zeroes being entered into the number as usual.

The zero key will act conventionally for data entry of any other variable.

Lo Temp: Temperature value for the lowest analog input. (i.e. input at 4 mA = 32 °F)

Hi Temp: Temperature value for the highest analog input. (i.e. input at 20 mA = 1000 °F)

Base reference Temperature: Temperature value at which the specific gravity reference value is measured. (i.e. 60 °F) A Base Reference point required for proper calculation in liquid applications.

Lo / Hi alarms: Temperature Values programmed at which the unit activates an alarm relay.

3.8.3 Setting the Flow Variables

The Flow variables determine how the input signals from Channel 3 or the Pulse Input are interpreted, Constant values are also entered in as needed. The Flow sub-menu varies with the computation or hardware selections you have previously made.

There are 45 different combinations of hardware and computation settings. General menus will be given in this manual. All variables will be shown. Be sure to observe notes as to which variables will be used in your situation.

SIXTEEN POINT

The setup procedure for the Sixteen Point sub-menu is covered in Chapter 4. Please review that chapter before attempting to program a Sixteen Point setup.

Refer to the following sections for your particular setup:

Hardware Setup	Page
3.8.3a Digital Linear Input Settings	3-15
3.8.3b Digital 16 Point Input Settings	3-16
3.8.3c Analog Linear Input Settings	3-17
3.8.3d Analog Orifice/Pitot Input Settings	3-18
3.8.3e Analog 16 Point Input Settings	3-19
3.8.4 Definitions of Flow Parameters	3-20

CHAPTER 8 RS-232 OPERATING INSTRUCTIONS

CHAPTER CONTENTS PAGE NUMBER:

GENERAL	8-2
Setting Up the RS-232 Link.....	8-2
Line Oriented Data Input	8-3
Parser	8-3
Line Editing	8-4
Protocol	8-4
Getting Started	8-4
COMMAND CATEGORIES	8-5
SET Command.....	8-6
Specific PARAMETER SET Commands.....	8-9
Using the SET Command	8-9
EXAMINE Command	8-16
RUN Command	8-18
STOP Command	8-19
CLEAR Command	8-19
LOCK / UNLOCK Commands	8-19
SYSDUMP Command	8-20
X Command	8-20
EXCEPTION REPORTING	8-21

7.2 Pulse Inputs are not Counting on the Instrument

A. Check the voltage of the pulses. They must be between 3-30V, and not less than 3 V or negative.

B. Check pulse width. Pulse width of the signal must be consistent with the filter that you have selected. If this is not the case, change the filter value.

7.3 Instrument Needs to be Totally Re-initialized to Clear Out the Memory.

Power up the instrument and press the **A** and the **CLR** keys at the same time. This will totally reinitialize the instrument. All parameters will be reset to their default values. The unit will require you to input the parameters that have null values and select the various options available.

3.8.3a Digital Linear Input Settings

Graphical representation of the Digital Linear sub-menu

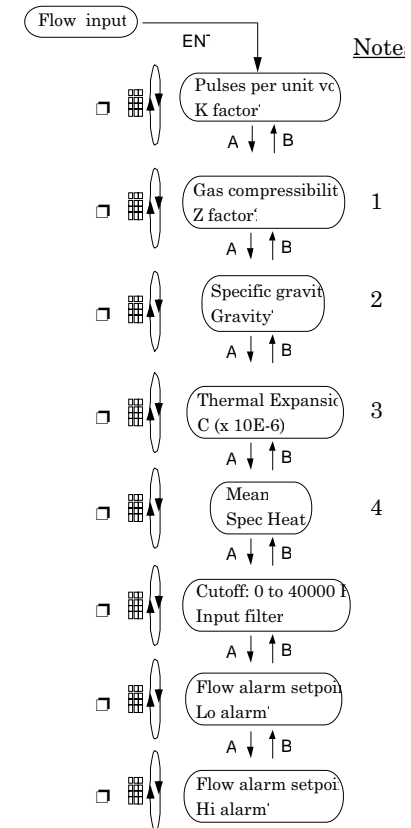

Notes:

- 1: Used in Ideal gas equations only.
- 2: Not used in Ideal gas - Volume or Steam equations.
- 3: Used in Liquids equations only.
- 4: Used in Gas - Heat, Liquid - Heat and Liquid - Del Heat equations only.

3.8.3b Digital 16 Point Input Settings

Graphical representation of the Digital 16 Point sub-menu

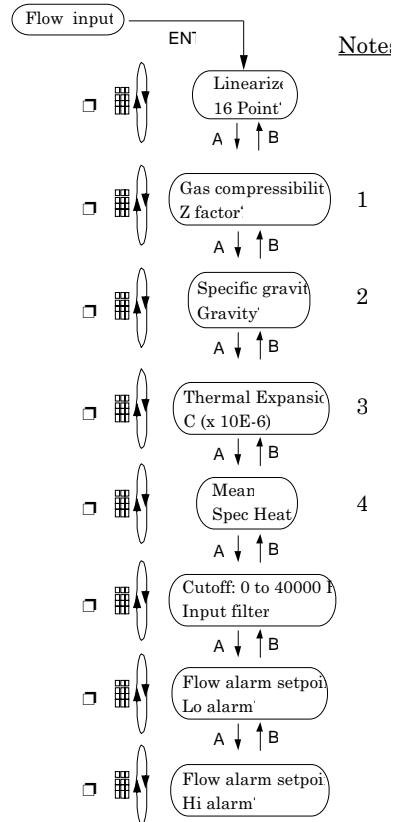

Notes:

- 1: Used in Ideal gas equations only.
- 2: Not used in Ideal gas - Volume or Steam equations.
- 3: Used in Liquids equations only.
- 4: Used in Gas - Heat, Liquid - Heat and Liquid - Del Heat equations only.

Chapter 7.0

Trouble Shooting Guide

7.1 Operator Forgets Security Lockout Code

If the authorized programmer of the instrument forgets the security code for the instrument and is locked out, follow this procedure:

- A. Scroll through the menu to the Lock/Unlock menu. Press the **ENT** key.
- B. At the prompt, enter the code 00000 using the keypad.
- C. The instrument will display a message "CALL IN CODE" and a 5-digit number. (Leave unit running with this display showing)
- D. Call the manufacturer and ask for the proper Customer Service personnel.
- E. Customer Service will ask for the 5-digit CALL IN CODE and will give you back a 5-digit RETURN CODE that was generated by a computer.
- F. Enter this 5-digit RETURN CODE using the keypad.
- G. You will have 5 chances to enter the RETURN CODE, after which this procedure will have to be repeated.
- H. Once the new 5-digit code has been successfully entered, it will unlock the Flow Computer.
- I. It will be your responsibility to reset the instrument with a new 5-digit lockout code.
- J. If, at a later date, you are locked out of the instrument again, you will have to call again and repeat this procedure, a new "CALL IN CODE" will be generated by the instrument.

CALCULATING THE C FACTOR: (Coefficient of Expansion)

The liquid density is a function of the flowing temperature for many fluids. This unit solves an equation which represents this physical property of the fluid.

The information which the unit uses to describe the fluid is entered by the user in the following variables: Reference Temperature, Reference Specific Gravity, Expansion Coefficient

This information is available for many fluids in one or more of the following forms:

- Fluid Specific Gravity vs. Temp. Table
- Specific Gravity vs. Temp. Graph
- Fluid Density vs. Temp. Table
- Fluid Density vs. Temp. Graph

Begin by obtaining one of the fluid properties for the fluid you are using from available manufacturers information or Engineering Handbooks. In some cases this information is listed on the Material Safety Data Sheet for the fluid.

Two temperature-specific gravity pairs will be required to compute the temperature coefficient.

The reference temperature is simply chosen by the user. Common reference temperatures are 60° F or 15° C.

However, for cryogenic fluids, the normal boiling point may also be used. In some cases the fluid data may list properties at 100° F, this temperature may also be used as the reference temperature.

The reference temperature should be chosen so that it is in the application temperature range. i.e. application temperature range -10 to 120° F, reference temperature of 60° F chosen.

Enter the reference temperature you have chosen at this point.

The reference specific gravity corresponds to the fluid SPECIFIC GRAVITY (not Density) at the reference temperature chosen.

You must convert the fluid density information to specific gravity if it is in units other than specific gravity. Use EQ1.

EQ1.

$$\text{Spec.Grav.} = \text{Density of Fluid} / \text{Density of Water}$$

Given the reference temperature, reference specific gravity, a second temp. and a second Spec.Grav., the C Factor can be computed as follows:

EQ2. Used for Liquid Corrected Volume Equation

$$C = \left[\frac{1 - (\text{Spec.Grav.2} / \text{Ref.Spec.Grav.})}{\text{Temp.2} - \text{Ref.Temp}} \right] \times 1,000,000$$

EQ3. Used for Liquid Mass and Heat Equations

$$C = \left[\frac{1 - (\text{Spec.Grav.2} / \text{Ref.Spec.Grav.})}{\text{Temp.2} - \text{Ref.Temp}} \right] \times 1,000,000$$

3.8.3c Analog Linear Input Settings

Graphical representation of the Analog Linear sub-menu

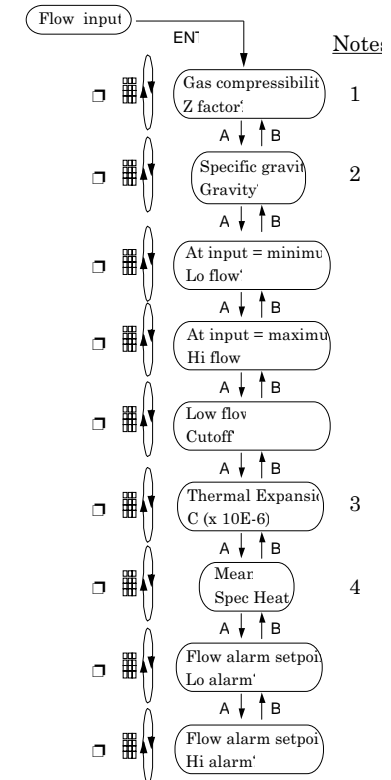

Notes:

- 1: Used in Ideal gas equations only.
- 2: Not used in Ideal gas - Volume or Steam equations.
- 3: Used in Liquids equations only.
- 4: Used in Gas - Heat, Liquid - Heat and Liquid - Del Heat equations only.

3.8.3d Analog Orifice/Pitot Input Settings

Graphical representation of the Analog Orifice/Pitot sub-menu

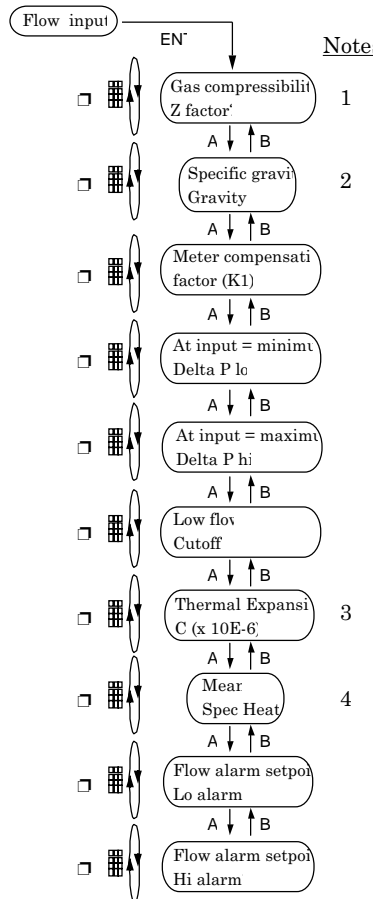

- Notes:
- 1: Used in Ideal gas equations only.
 - 2: Not used in Steam equations.
 - 3: Used in Liquids equations only.
 - 4: Used in Gas - Heat, Liquid - Heat and Liquid - Del Heat equations only.

FORMULAS:

GAS:

English

$$K1 = \text{ACFM} \times \text{sqrt}[(\text{SG} \times \text{PSIA}) / (\text{Z} \times \text{T} \times \text{inH}_2\text{O})]$$

$$K1 = \text{SCFM} \times 0.028279 \times \text{sqrt}[\text{SG} \times (459.67 + ^\circ\text{F}) \times \text{Z} / (\text{PSIA} \times \text{inH}_2\text{O})]$$

$$K1 = \text{PPM} \times 0.370532 \times \text{sqrt}[(459.67 + ^\circ\text{F}) \times \text{Z} / \text{SG} \times \text{PSIA} \times \text{inH}_2\text{O}]$$

Metric

$$K1 = (\text{NM}^3/\text{h}) \times (0.3123483) \times \text{sqrt}[(\text{SG} \times \text{Z} \times \text{T}) / (\text{Kpa} \times \text{mmH}_2\text{O})]$$

STEAM:

English

$$K1 = \text{ACFM} / \text{sqrt}[2.698825 \times \text{SVOL} \times \text{inH}_2\text{O}]$$

$$K1 = \text{PPH} \times 0.0101452 \times \text{sqrt}(\text{SVOL} / \text{inH}_2\text{O})$$

Metric

$$K1 = 0.451592 \times \text{Kg/hr} \times \text{sqrt}(\text{SVOL} / \text{mmH}_2\text{O})$$

LIQUID:

English

$$K1 = (\text{GPM} \times 0.642625) \times \text{sqrt}[\text{SG} / \text{inH}_2\text{O}]$$

$$K1 = \text{PPM} \times 0.077079 / \text{sqrt}(\text{SG} \times \text{inH}_2\text{O})$$

Metric

$$K1 = 51.36577 \times \text{liter/sec} \times \text{sqrt}(\text{SG} / \text{mmH}_2\text{O})$$

WHERE :

ACFM = Actual Cubic Feet Per Minute

SG = The Specific Gravity @ base conditions

PSIA = PSIG + Barometric pressure

Z = Gas Compressibility Factor

T = $^\circ\text{F} + 459.67$ or $(^\circ\text{C} + 273.17)$

inH₂O = Inches of Water from Differential Pressure Device

mmH₂O = Millimeters of Water from Differential Pressure Device

SCFM = Standard cubic feet/ minute (i.e. at 60°F, 14.696 PSI)

lbm/min = Pounds-Mass per minute = (lbm/hr ÷ 60)

sqrt[] = take the square root of what is inside the brackets

SVOL = Specific Volume at operating pressure and temperature.
English = ft³/lb Metric = M³/Kg

PPM = Pounds per Minute

PPH = Pounds per Hour

CORRECTED VOLUME FLOW CALCULATIONS

Gas English:

$$(PSIA/14.696) \times (519.67/TEMP+459.67) \times (1/Z) \times UCFLOW = VOL$$

Where reference conditions = 60°F, 14.696 PSIA

Gas Metric:

$$(KPa/101.329) \times (273.15/TEMP+273.15) \times (1/Z) \times UCFLOW = VOL$$

Where reference conditions = 0°C, 101.325 KPA

Liquid:

$$UCFLOW \times [1-C \times (Tf - Tref)] = VOL$$

MASS FLOW CALCULATIONS

$$UCFLOW \times DENSITY = MASS$$

HEAT FLOW CALCULATIONS

Gas/Liquid English:

$$MASS \times SH \times (TEMP + 459.67) = HEAT$$

Gas/Liquid Metric:

$$MASS \times SH \times (TEMP + 273.15) = HEAT$$

Steam:

$$\text{Specific Enthalpy} \times MASS = HEAT$$

Del Heat Liquid:

$$MASS \times SH \times (TEMP1 - TEMP2) = HEAT$$

6.5 K1 Factor Calculation

The K1 factor is used in Orifice/Pitot/Annubar calculations. The K1 factor is the calibration factor for the meter run. It is part of the Variables menu for flow input values (analog). To calculate the factor take known conditions from calibration and apply them in the appropriate formula on the following page to solve for K1. A diskette program is available to assist in the computation of the K1 term.

3.8.3d Analog 16 Point Input Settings

Graphical representation of the Analog 16 Point sub-menu

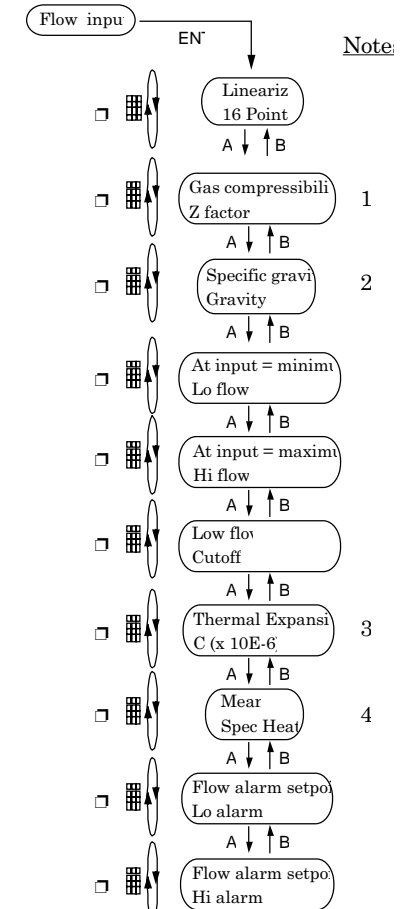

Notes:

- 1: Used in Ideal gas equations only.
- 2: Not used in Ideal gas - Volume or Steam equations.
- 3: Used in Liquids equations only.
- 4: Used in Gas - Heat, Liquid - Heat and Liquid - Del Heat equations only.

3.8.4 Definitions of Flow Parameters.

K factor: Pulse per unit volume divider. For example if 100 pulses are input for 1 unit volume (i.e. cu.ft. or gal) a K factor of 100 will be used.

$$\text{Display Value} = \frac{\text{Number of Pulses}}{\text{K Factor}}$$

Z factor: Compressibility factor of a gas.

Specific gravity: Constant for the material being measured calculated at Standard or the Base Reference Temperature.

K1 factor: Compensation factor used in making Orifice/Pitot calculations. Refer to K1 Factor calculations (See Chapter 6).

Lo flow/Delta P lo: Flow value or differential pressure value for Linear or Orifice/Pitot measurement respectively at which the analog value input is lowest.

Hi flow/Delta P hi: Flow value or differential pressure value for Linear or Orifice/Pitot measurement respectively at which the analog value input is highest.

Lo flow Cutoff: Lowest uncompensated flow value below which any calculations are unnecessary. For Example:

- i) A small leakage when valve is closed, to be ignored.
- ii) Inaccuracy at lowest end of square law measurements.

C factor ($\times 10^{-6}$): Thermal coefficient of expansion for liquid being measured. Related to liquids flow equation and target liquid characteristics. (see Chapter 6)

Mean Spec Heat: Constant value for the ability of a fluid to retain heat. A high value for good heat retention.

Cutoff: 0 to 40000 Hz: Highest pulse rate which the unit will accept pulses. Higher pulse rates are ignored. This is accomplished by hardware and software filters.

Lo/Hi alarm: Compensated Flow values at which the unit activates relay output.

Input Calculations

Temperature:

$$\text{temp lo} + [(\text{temp hi} - \text{temp lo}) \times (\%)] = \text{Tf}$$

Pressure:

$$\text{press lo} + [(\text{press hi} - \text{press lo}) \times (\%)] = \text{Pf}$$

Analog-Orifice/Pitot:

$$\text{Delta P lo} + [(\text{Delta P hi} - \text{Delta P lo}) \times (\%)] = \text{DP}$$

DENSITY CALCULATIONS

Density-Liquid (liquid volume eq):

$$\text{SG} \times \text{DENSITY H}_2\text{O} \times [1 - (\text{C} \times 1.0 \times 10^{-6} \times (\text{Tf} - \text{Tref}))] = \text{DENSITY}$$

Density-Liquid (liquid mass eq):

$$\text{SG} \times \text{DENSITY H}_2\text{O} \times [1 - (\text{C} \times 1.0 \times 10^{-6} \times (\text{Tf} - \text{Tref}))]^2 = \text{DENSITY}$$

Density-Steam:

$$1/\text{SV} = \text{DENSITY}$$

Density-Gas English:

$$(2.698825 \times \text{SG} \times \text{PSIA})/(\text{Z} \times \text{TEMP} + 459.67) = \text{DENSITY}$$

Density-Gas Metric:

$$(3.483407 \times \text{SG} \times \text{kPa})/(\text{Z} \times \text{TEMP} + 273.15) = \text{DENSITY}$$

UNCORRECTED VOLUME FLOW CALCULATIONS

Digital:

$$(\text{Hz/K}) \times (60 \text{ sec}/1 \text{ min}) = \text{UCFLOW}$$

Analog-Linear:

$$\text{Lo Flow} + [(\text{Hi Flow} - \text{Lo Flow}) \times (\%)] = \text{UCFLOW}$$

Orifice/Pitot Calculation English:

$$\text{K1} \times \frac{\text{SDP}}{(\text{DENSITY} \times 0.3705316202)} = \text{UCFLOW (in ACFM)}$$

6.4 Flow Calculations

If the analog flow input has been selected, the raw flow value is digitized from Channel 3 and then scaled according to the two keyable scale factors to calculate the instantaneous flow over the interval. If the digital pulse input is selected, the value provided by the digital input pulse accumulator is divided by the K factor to find the instantaneous flow over the interval. The result is then filtered according to the keyed in flow filter parameter to get the uncompensated flow.

Definition of Terms

TREF: Base Reference Temperature entered by user.

C: Thermal coefficient of expansion for the liquid media ($\times 10^{-6}$).

DENSITY: Density as calculated from parameters and inputs.

DP: Differential pressure calculated from flow input in inches of water or millimeters of water.

Hz: Input frequency in cycles per second.

K: The meter calibration factor in pulses per ft³, gal, M³ or liter

K1: Orifice/Pitot/Annubar Calibration Factor (See Section 6.5)

kPa: The absolute pressure (Gage pressure + Barometric pressure).

MASS: Mass flow rate from calculations using temperature, pressure and flow. Del Heat equation uses temp1 for mass calculations.

PSIA: The absolute pressure (Gage pressure + Barometric pressure).

PSIG: Upstream gage pressure calculated from input.

SG: Specific Gravity as entered by user with respect to Standard conditions or the Base Reference temperature

SH: Specific Heat as entered by user or from Steam Tables.

SV: Specific Volume from Steam Tables.

TEMP: Temperature as calculated from input.

UCFLOW: Uncompensated flow as determined by calculations.

VOL: Corrected Volumetric Flow as determined by calculations.

Z: Mean Gas compressibility factor as entered by user.

% Input signal as percentage of span

3.8.5 Setting the Flow Output Variables

The Flow Output variables determine how the output signals reflect the compensated flow. The Flow Output sub-menu is the same no matter which computation or hardware selection you have previously selected.

Notes:

It is not necessary to setup the Flow Output if it is not required. If setup, the analog out terminal must be connected to a loop to avoid alarm relay from activating.

Graphical representation of the Flow Output sub-menu

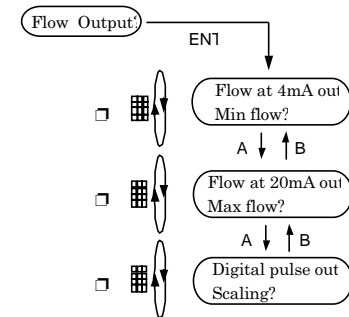

Min flow (4mA): The compensated flow rate value to be represented by the 4 mA end of the 4 to 20 mA output.

Max flow (20mA): The compensated flow rate value to be represented by the 20 mA end of the 4 to 20 mA output.

4-20 mA Example: 4 mA = 10; 20 mA = 1000;

The Flow Computer will sink 4 mA from a flow rate of 0 to 10. Then it will linearly ramp up to 20 mA; as the flow increases to 1000 (The current will clamp at 20mA even though the flow may exceed 1000, until the flow drops back into the active range.)

Digital pulse out Scaling: Multiplying factor for digital output. Based on the flow totalizer, this factor multiplies the incremental counts of the totalized flow and gives a pulse out as required. For example: A factor of 0.1 puts one pulse out for every 10 increments of the flow totalizer ($0.1 \times 10 = 1$).

3.9 Clearing the Totalizer

The totalizer can be cleared on either side of the menu, (Stand by or Running). The totalizer only accumulates while in the Running side of the menu.

DISPLAY	PRESS
Run?	A
Set Hardware?	A
Set Computations?	A
Set Variables?	A
Clear Totalizer?	ENT

The words "Totalizer Cleared" are displayed momentarily, then, the menu advances to Check Alarm.

Check Alarm?

On the RUNNING side of the menu, you have another opportunity to clear the totalizer:

DISPLAY	PRESS
Running... Show Data?	A
Running... Go To Standby?	A
Running... Setup Data Display?	A
Running... Setup print list?	A
Running... Print system setup?	A
Running... Clear Totalizer?	ENT

The words Totalizer Cleared are displayed momentarily, then, the menu returns to . . .

Running... Show Data?	
--------------------------	--

Clear Totalizer: Resets totalizer to 0.0

Chapter 6.0

6.0 Principles of Operation

6.1 General:

This chapter explains in detail how the instrument calculates mass flow based on specific data input.

Each parameter is updated at a 2Hz rate. Therefore, all references to the machine's "interval" in the following descriptions indicate a period of 0.5 seconds.

In metric modes, all metric values are converted to English units internally. The English equations are used to calculate results. The results are then converted to their metric equivalent for display.

6.2 Temperature Calculations

If an RTD is used as a temperature transducer, the computer runs a constant current through both the RTD and the internal precision resistor it is in series with (See Section 5.12). The computer then measures the voltage drop across each individually and calculates a ratio, thus determining the actual resistance of the RTD. A look up table is used to linearize and convert the ohmic reading to degrees F.

Any other type of temperature transducer must present a voltage or current to Channel 1 of the computer. This value is filtered, digitized and scaled based on the keyed in temperature parameters. The value is checked against keyed in alarm limits and the alarm relay is activated if necessary.

6.3 Pressure Calculations

Any pressure transducer must present a voltage or current to Channel 2 of the computer. The raw pressure value is digitized from Channel 2 and then scaled according to the two scale factors to calculate the actual pressure. The value is checked against keyed in alarm limits and the alarm relay is activated if necessary.

5.5 Case Dimensions

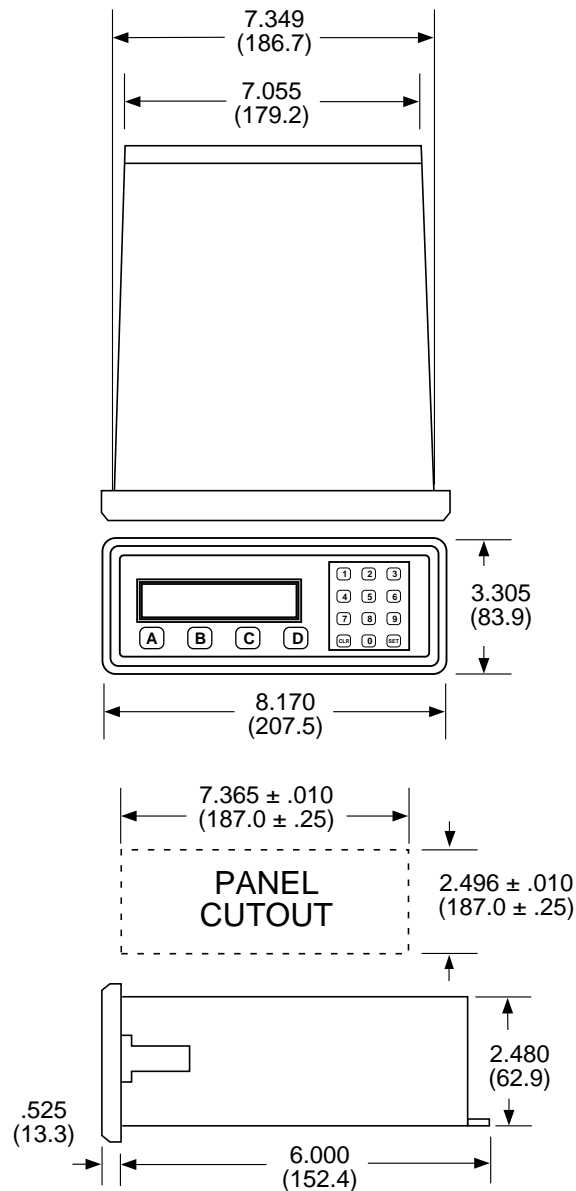

3.10 Checking the Alarm

If the alarm should go off anytime during the Stand by or Running modes of the Flow Computer, you can easily check which point has most recently gone into alarm by following these menu steps:

DISPLAY	PRESS
---------	-------

Run?	A
------	----------

Set Computations?	A
-------------------	----------

Continue Pressing A until	
----------------------------------	--

Clear Totalizer?	A
------------------	----------

Check Alarm?	ENT
--------------	------------

(Alarm Condition Shown)
Press ENT to quiet.

This procedure will have to be completed for each alarm condition. Until No Alarm Condition is shown. In which case the menu will advance to . . .

Lock / Unlock?	
----------------	--

Check Alarm: Used to view the most recent alarm condition. See appendix iv for possible alarm conditions.

On the RUNNING side of the menu, you have another opportunity to check an alarm condition:

DISPLAY	PRESS
---------	-------

Running... Show Data?	A
--------------------------	----------

Running... Go To Standby?	A
------------------------------	----------

Continue Pressing A until	
----------------------------------	--

Running... Examine Variables?	A
----------------------------------	----------

Running... Alarm Check?	ENT
----------------------------	------------

(Alarm Condition Shown)
Press ENT to quiet.

This procedure will have to be completed for each alarm condition. Until No Alarm Condition is shown. In which case the menu will return to . . .

Running... Show Data?	
--------------------------	--

3.11 Locking and Unlocking the Flow Computer

Lock / Unlock is used to prevent unwanted changes in programming. Changes through the front panel or RS232 port cannot be made when the unit is locked.

DISPLAY	PRESS
Run?	A
Set Computations?	A
Engineering Units?	A
Continue Pressing A until	
Check Alarm?	A
Lock/Unlock?	ENT

Machine is unlocked.
Enter code: You enter a 5 digit —> 1 2 3 4 5 code number.

Machine is unlocked.
Enter code: *****

NOTE: Code number may be any number except 00000

Machine is unlocked.
Now confirm: Re-enter 5 digit code —> 1 2 3 4 5 number.

Machine is unlocked.
Now Confirm: ***** After confirming, Flow Computer will revert to menu.

Run?

5.24 Auxiliary Power Output

Voltage:	24VDC regulated and filtered
Isolation:	230VAC max
Current:	0 to 100mA
Protection:	Short Circuit Proof

5.3 RS232 Communications Port

(See Section 8 for more information on RS232 Option.)

Connector:	25 Pin Female (DB25S)
Input Impedance:	3000 Ω to 7000 Ω
Compliance Voltage:	
Output:	-25 to -5 (Mark); 5 to 25 (Space); Volts
Input:	-25 to -3 (Mark); 3 to 25 (Space); Volts
Protection:	Short circuit proof.
Protocol:	8 bits, 1 Stop bit
Parity:	None (Not monitored)
Available Baud Rates:	300, 1200, 9600

RS232 Connector Pin Out

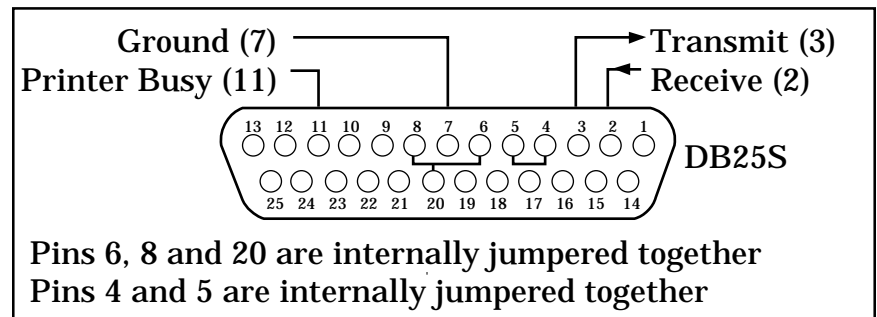

5.4 Data Display and Keypad

Internal 2 line by 20 character dot matrix LCD display. Sealed, 16 key panel featuring numeric keys 0- 9, plus the following keys:

- A Advance through menus
- B Back up through menus
- C Cancel current menu selection
- D Decimal point key
- ENT . General purpose enter or recall data key
- CLR . Data clear key

Output Frequency Range: 0 to 50KHz
 Max Output Slew Rate: 27 Volts/ μ sec
 Sustained Fault Voltage for no permanent damage: 7 Volts
 Transient Protection: 1500V 50 μ sec

Pulse Output Schematic

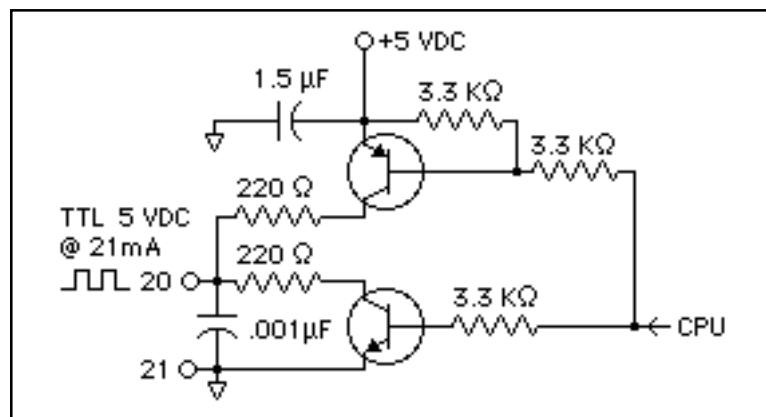

5.23 Relay Outputs

One relay is provided as a combination hi/lo flow alarm output and a second is provided for alarm conditions. Each has the following electrical specifications:

Type: Dry Contact, Form C
 Contact Rating: 10A @ 115/230VAC/28VDC

Typical Relay Output Schematic

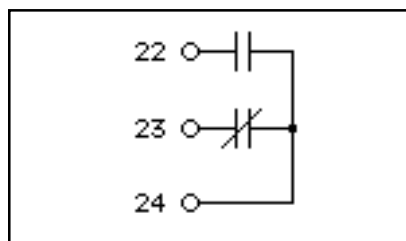

After the lock has been established in the Flow Computer, and the operator tries to change one of the operating parameters, he will get the following message:

**** Locked!! ****
 Push ENT to continue

To UNLOCK the machine, repeat the process described above. When unlocking the machine, no confirming step is needed. **The five digit code number should be placed in a safe location.**

Note that you can also lock or unlock the machine from the RUNNING side of the menu.

DISPLAY

PRESS

Running...
 Show Data?

A

Running...
 Go To Standby?

A

Continue Pressing **A** until

Running...
 Alarm Check?

A

Running...
 Lock / Unlock?

ENT

Follow procedure on previous page.

If you lock yourself out of the Flow computer, and you have forgotten the security code, access can be gained by entering a security code of 00000. The Flow Computer will prompt you with a call in code. Call the service number on the cover of this manual and ask for customer service. A one time matching unlock code will be given to you. Enter it to unlock the Flow Computer.

3.12 Setting the Real Time Clock

The instrument has a real time clock/calendar that can be set from the front keypad.

The time and date are saved upon power down. However, there is no battery back up in the Flow Computer to update the time and date during loss of power. For this reason, if you are using this feature, the time and date must be reset upon each power up.

To do this, follow the menu listed below:

DISPLAY	PRESS
Run?	A
Set Computations?	A
Continue Pressing A until	
Check Alarm?	A
Real time clock?	ENT
Select Item: Set Time?	ENT
Enter time: hr.min ?	i.e. 14.32
Enter time: hr.min ? 14.32	ENT

Remember that when entering the time for the real time clock, it must be in 24 hour format.

Set Time: Hours (00 to 23) and minutes (00 to 59) based on 24 hour clock.

5.2 Output Specifications

5.21 Analog Outputs

Number:	1
Range:	4-20mA DC, sink only
Compliance Voltage Range:	3.0-24 VDC
Load Type:	Non Inductive
Accuracy:	+/- 0.5% FS
Update Rate:	1Hz

Analog Output Schematic

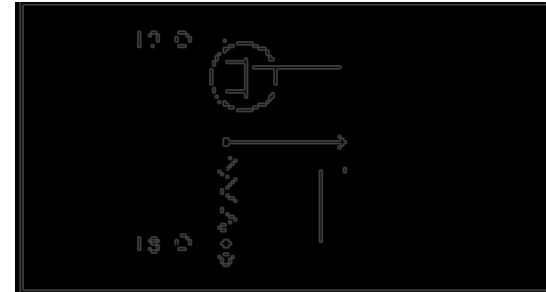

5.22 Digital Flow Pulse Output

This output is intended to drive a counter with a minimum input impedance of 1000 Ω . It is also compatible with TTL, LSTTL and 5V CMOS logic inputs. It is slew rate limited to help reduce RFI.

Number:	1
Output High Voltage	
No load:	4.5 Volts min
4.0 mA source:	4.0 Volts min
Output Low Voltage	
No Load:	0.2 Volts max
4.0 mA sink:	1.0 Volts max
Output waveform:	

Symmetric square wave above 5 Hz
100msec pulse below 5 Hz

Typical RTD Input Schematic

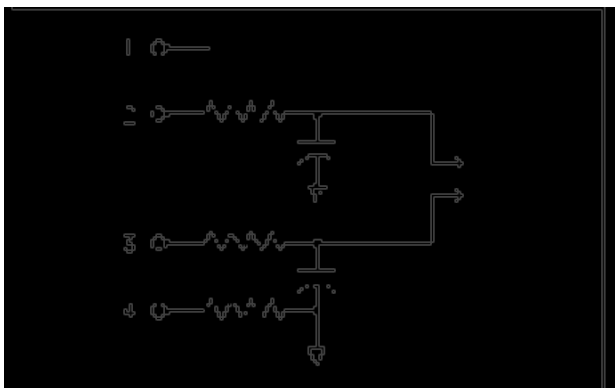

5.13 Digital Flow Input:

Number: 1 (Flow only)
 Range: 3-30 VDC Pulse
 Sensor Types: Dry contact, opto-isolated or voltage source
 Max Input Frequency: 40kHz max
 Min pulse width: 10µsec (with 40kHz filter)
 Thresholds: OFF is less than 2.0V
 ON is greater than 2.5V
 Input Impedance: 40K Ω to ground minimum
 Excitation Voltage: 5VDC through 5.6K Ω resistor
 Min. Frequency to maintain rate display: 5 Hz

Typical Digital Pulse Input Schematic

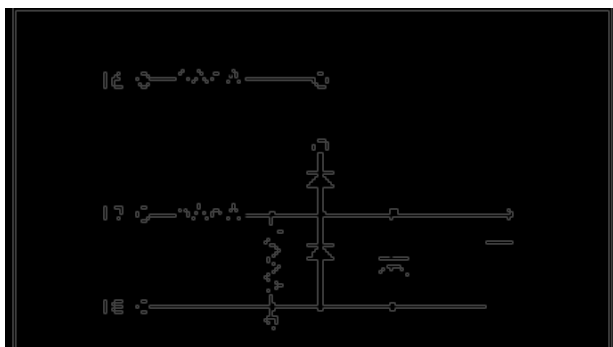

After you have set the time, you should repeat the menu shown above, and set the date in the instrument.

DISPLAY	PRESS
Run?	<input type="button" value="A"/>
Set Computations?	<input type="button" value="A"/>
Continue Pressing <input type="button" value="A"/> until	
Check Alarm?	<input type="button" value="A"/>
Real time clock?	<input type="button" value="ENT"/>
Select item: Set Time?	<input type="button" value="A"/>
Select item: Set Date?	<input type="button" value="ENT"/>
Enter date: mo.da.yr ?	i.e. 2.16.90
Enter date: mo.da.yr ? 2.16.90	<input type="button" value="ENT"/>

Entering an invalid time or date will cause an error message to be displayed. Such as
 Bad Time value (or Bad Date value)
 Push ENT to continue

After entering the date the menu will advance to
 Serial interface?

Set Date: Month (01 to 12), Day (01 to 31) and Year (00 to 99).

3.13 Setting the Serial Interface

Setting up the Serial Interface is only important if you have an RS-232 communication card option installed in the instrument.

The first thing that you are asked for is the unit identification number. You have a choice of identifying the unit with a unique whole number between 1 and 99. To set the Unit Identification Number follow the menu shown below:

DISPLAY	PRESS
Run?	A
Set Computations?	A
Continue Pressing A until	
Real time clock?	A
Serial Interface?	ENT
Serial Interface: Unit ID?	ENT
1-99: Unit ID?	i.e. 3

Entering an invalid ID number will cause the following error message to be displayed.
 Bad ID value
 Push ENT to continue

Display advances to next menu item when **ENT** is pressed.

Serial Interface:
Baud Rate

Typical Current Input Schematic

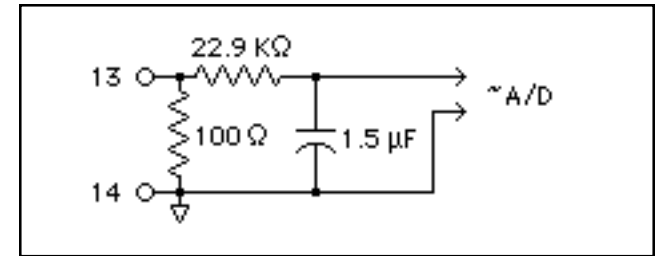

Voltage Input

Input Impedance: 100K Ω
 Range: 0-5V, 0-10V
 Resolution: $\pm 0.024\%$ FS

Typical Voltage Input Schematic

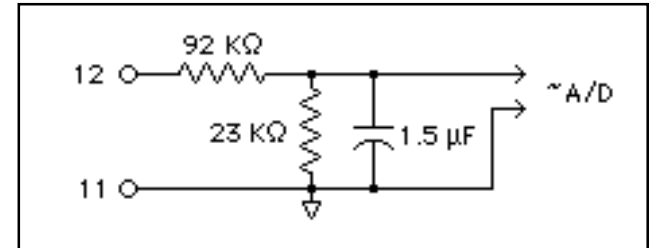

5.12 RTD Temperature Inputs

Compatible RTD type: 100 Ω Platinum
 (a = 0.00385: DIN 43-760 Calibration)
 Suitable for use with: 2, 3 or 4 wire RTD's
 Excitation Current: 2mA typical
 Max Fault Current: 15mA
 Max Voltage on sense inputs: 50 VDC
 Rejection of 50 or 60Hz signal: 40dB (minimum)
 (Automatically based on line frequency)
 Raw Accuracy: 0.5 $^{\circ}$ C
 Temperature Range: -323.5 to +1378.7 $^{\circ}$ F
 (-197.5 to +748.1 $^{\circ}$ C)

Lead Wire Compensation: 4 Wire

Four wire field wiring required for 2,3 and 4 wire RTD's

See schematic next page.

Chapter 5

5.0 General Specifications

5.01 Environmental

Operating Temperature: 32 to 122 F (0 to 50 C)
Storage Temperature: -10 to 160 F (-23 to 71 C)
Humidity: 0 to 90% Non-condensing
Front Bezel: NEMA 4X
Case: ABS Plastic
Dimensions: See page 5-7

5.02 Input Power

Voltage: 115 or 230 VAC $\pm 15\%$ (Switch Selectable)
24VDC $\pm 20\%$
12VDC $+20\%$, -10%
Frequency: 50/60Hz.
Power Consumption: 10 Watts max

5.1 Input Specifications

The following applies to all inputs in all modes. Inputs are referenced to the signal ground. All ground terminals are connected internally. The exception is the RTD input which is differential but is referenced to ground.

Transient protection: 100V 5nsec

Note: In the event of the specified fault conditions, unit may temporarily malfunction, but no permanent damage will occur.

5.11 Analog Inputs

Temperature, Pressure, and Flow (1 each)

Current Input:

Input Impedance: 100 Ω
Range: 0-20mA, 4-20mA

Maximum sustained input voltage: 5 VDC (Fault Condition)
Resolution: $\pm 0.024\%$ FS

The next menu item is the Baud Rate.

Graphical representation of the Baud Rate sub-menu

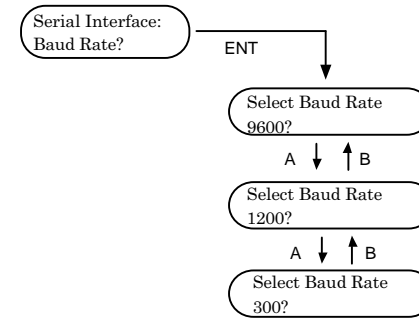

You have a choice of three Baud Rates.

Note: The unit cannot be accessed through the front keypad or via the Serial Port while data is being transmitted out from the unit. A baud rate of 300 may cause an undesirable delay in access. This is especially true when the print list is lengthy.

Display advances to next menu item when **ENT** is pressed.

The next item is the Print Interval:

DISPLAY	PRESS
Serial Interface: Baud Rate?	A
Serial Interface: Print Interval?	ENT

The Print Interval is the time between automatic print-outs. For more information on the Print Interval see Chapter 8.

(in minutes)

Print interval? i.e. 15

Note: The print interval can be 0.25 minutes to 1440 minutes (1 day). Any value out of this range, will inhibit the automatic serial output of the list that is set up in the Run Menu.

The option to activate the serial port is chosen next. This menu directly follows the Print Interval selection.

DISPLAY	PRESS
Serial Interface: Print Interval?	A
Serial Interface: On/Off Line?	ENT

Graphical representation of the On/Off Line sub-menu

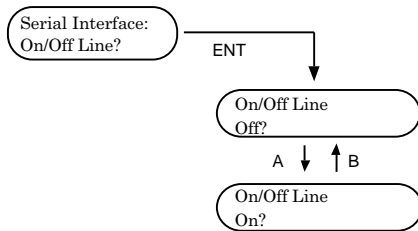

The option to print out alarm conditions automatically when they occur, is also available on units with the RS232 option. This menu directly follows the On/Off Line selection.

DISPLAY	PRESS
Serial Interface: On/Off Line?	A
Serial Interface: Exception Reporting?	ENT

Graphical representation of the Exception Reporting sub-menu

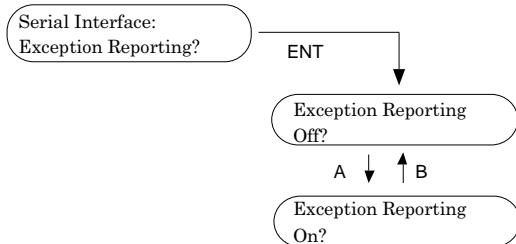

4.4 16 Point Calculations

The 16 Point routine uses the entered data to determine the K factor for any given input frequency or input flow signal. This is done by taking the closest data points above and below the input signal, then using those points to extrapolate the K factor, then calculating the uncompensated flow from the data. Below are the formulas.

Parameters:

Determine closest point above input signal
 signal = X, K factor = KA

Determine closest point below input signal
 signal = Y, K factor = KB

Let input signal = H, unknown K factor = KN

To find KN use this formula:

$$\frac{H - Y}{X - Y} \times (KA - KB) + KB = KN$$

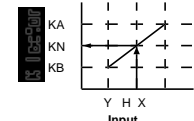

For example:

Using the values given earlier, with an input frequency of H = 15 Hz, yields

Determine closest point above input signal
 signal = 20 Hz, K factor = KA = 1.1111

Determine closest point below input signal
 signal = 10 Hz, K factor = KB = 1.25

$$\frac{15 - 10}{20 - 10} \times (1.1111 - 1.25) + 1.25 = 1.18055 = KN$$

Linearized flow input is

$$1.18055 \times \frac{15}{60} = 762.357 \text{ ACFM}$$

Programming begins as follows

To get to the Variables menu . . .

Display shows	Press
Run?	A
Set Computations?	A
Continually press A until . . .	
Set Variables?	ENT
Pressure input?	A
Temperature input?	A
Flow input?	ENT
Linearize 16 Point?	ENT

The data would be entered as follows

Enter Point Actual01?	00
Actual01? 0.0000 K Factor01?	1
Enter Point Actual02?	10

etc.

The Flow Computer prompts you for the actual input signal and a K factor to divide it by to yield true actual flow (i.e. 16 Point corrected ACFM).

The actual (apparent) flow has assumed units as follows:

Flow Equation	English	Metric
gas/steam	Actual ft ³ /min	Actual M ³ /hr
liquid	GPM	liter/sec

3.14 Crossing Over From Setup to Running Mode

Figure 3-4 shows the structure of the Running menu.

Cross over from the Setup mode to the Running mode of the instrument, and review the top level menu.

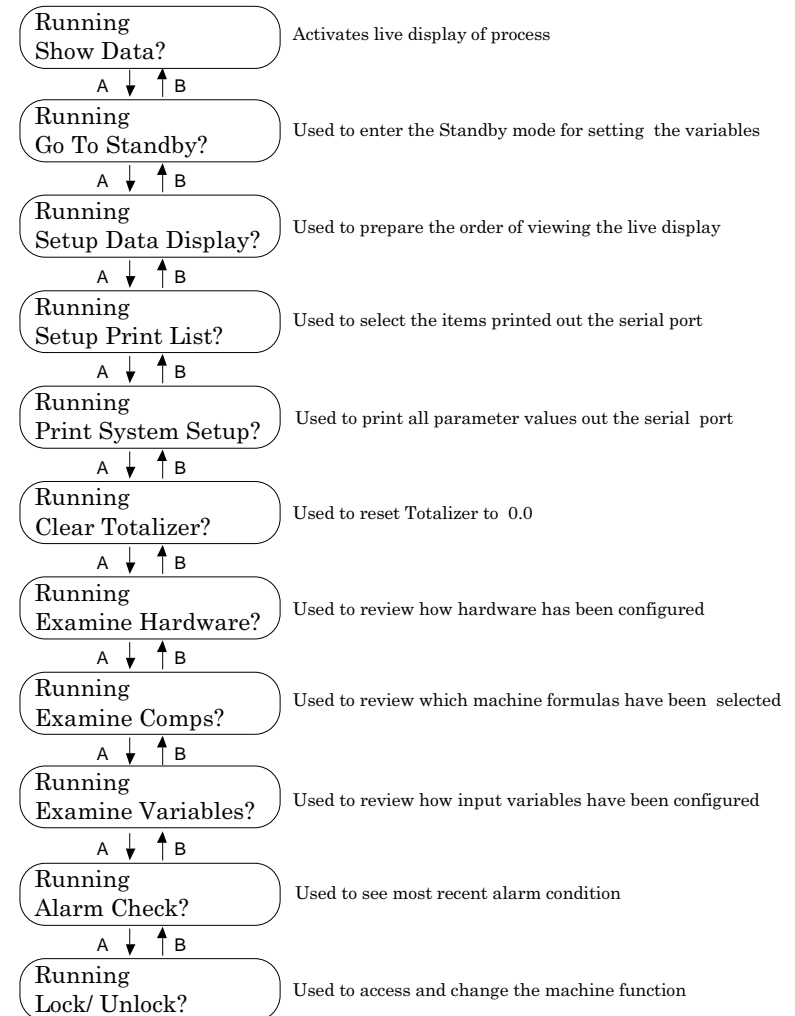

Figure 3-4

3.15 Show Data?

This menu item will start the data list scrolling on the front of the LCD display.

DISPLAY	PRESS
Run?	<input type="button" value="ENT"/>
Show Data?	<input type="button" value="ENT"/>
Set up list first!	
Push ENT to continue	

If you get the following, you have not set the display list of data, and should refer to Section 3.16.

3.16 Setting up the Data Display

During normal operation, the instrument may be set up to display the important operating data such as flow rate, temperature, or pressure. The following data can be scanned and displayed on the front panel of the instrument:

- | | |
|---------------------|---------------------------------------|
| 1. Time & Date | Current Time and Date |
| 2. Flow Rate | In rate units per minute or hour |
| 3. Mass Flow | In mass flow units per minute or hour |
| 4. Heat Flow | In heat flow units per minute or hour |
| 5. Totalizer (Flow) | Compensated accumulated flow |
| 6. Totalizer (Mass) | Compensated accumulated mass flow |
| 7. Totalizer (Heat) | Compensated accumulated heat flow |
| 8. Temperature | Scaled in engineering units |
| 9. Pressure | Scaled in engineering units |

Continued on next page.

Freq03?	20.0000	
K Factor03?		1.11111
Enter Point		
Freq04?		30
Freq04?	30.0000	
K Factor04?		1.017
Enter Point		
Freq05?		100
Freq05?	100.0000	
K Factor05?		1.000
Enter Point		
Freq06?		1000
Freq06?	1000.0000	
K Factor06?		1.000

Note: Since the K factors for the last two points are one, any frequency higher than 1000 Hz will be modified by a K factor of 1.

4.3 16 Point Analog Setup

Analog programming is same as the Digital setup. The Flow Computer asks for 16 different flow rates and 16 corresponding K factors (correction factors). It then uses this data to determine what the true flow is for any given actual (apparent) input signal. Again, a minimum of three points must be set up.

$$\text{K factor} = \frac{\text{Actual Input Flow}}{\text{True Flow}}$$

The same rules that applied for the Digital setup apply for the Analog setup as well.

Usually the necessary data is provided with the flowmeter. If not, your flowmeter must be calibrated for use. This can be done by selecting Digital Linear in hardware and setting your K factor to 1 in variables. By making various system runs with calibrated measurements, the actual flow verses the frequency input can be determined and K factors derived.

Below is some sample data that compensates for some low end inaccuracies. This sample is an illustrative example applicable to a gas application using English units.

Sample Data:

Input	Actual ft ³ /sec	K factor
Frequency	Actual flow	
0	0	1.0000
10	8	1.2500
20	18	1.1111
30	29.5	1.0170
100	100	1.0000
1000	1000	1.0000

The data would be entered as follows

Display shows	Press
Enter Point Freq01?	00
Freq01? 0.0000 K Factor01?	1
Enter Point Freq02?	10
Freq02? 10.0000 K Factor02?	1.25
Enter Point Freq03?	20

10. Uncompensated Flow Volumetric flow rate per minute
11. Raw Flow (Channel 3) Raw flow input (Value of Full Scale)
12. Raw Temperature (Channel 1 or 2) Raw temperature input (Value of Full Scale)
13. Raw Pressure (Channel 2) Raw pressure input (Value of Full Scale)
14. Raw RTD Input (Channel 1 or 2) Raw RTD input (Value in mA)
15. RTD Ohms (Channel 1 or 2) Resistance of RTD device
16. Analog Output Value in mA
17. Specific Volume Current Specific Volume (from Steam Tables)
18. Specific Enthalpy Current Specific Enthalpy (from Steam Tables)
19. Flow Frequency Raw pulse frequency in

The operator can designate the items of this list that will be displayed, and in which order they will be displayed. Each item will be displayed about two seconds. Additionally, each point can be displayed more than once in the scan list. If you find that a parameter is not being displayed long enough, select it twice in a row.

Note: The parameters available for display selection is dependent upon selections made in the Setup menu (Set Computations, Set Hardware and Set Variables). The system automatically determines the display based on programmed parameters.

Use the following menu to set up the list of items that you would like to be displayed while the machine is running:

DISPLAY

PRESS

Run?

ENT

Running . . .
Show Data?

A

Running . . .
Go to Standby?

A

Running . . .
Setup data display?

ENT

Select Item # 1
Time & Date?

A

Each time the **A** key is pressed the variables change. These variables are listed above.

Select Item # 1
Mass Flow?

ENT

Pressing the enter key selects that item for display. The Item# will increment as selections are made. Continue to advance or backup through the list of available items, making selections as you go along.

Select Item # 2
Totalizer?

ENT

Select Item # 3
Temperature

C

Pressing the **C** button exits from the routine back to Show Data?

4.2 16 Point Digital Setup

Digital programming is quite simple if values of frequency and flow are known. The Flow Computer asks for 16 different frequencies and 16 corresponding K factors. It then uses this data to determine what the actual flow is for any given input frequency.

Programming begins as follows

To get to the Variables menu . . .

Display shows	Press
Run?	A
Set Computations?	A
Continually press A until . . .	
Set Variables?	ENT
Once in the Variables menu, advance to the Flow input sub menu.	
Pressure input?	A
Temperature input?	A
Flow input?	ENT
Linearize 16 Point?	ENT

Enter Point
Freq01?

Data entry can now begin. Using the **A** and **B** keys you can advance or backup to any one of the 16 points. It is suggested that you start with point 01 and work your way up through the points.

The K Factor must be entered in the following units based on the flow equation:

Flow Equation	English K Factor	Metric K Factor
gas/steam	pulses/ft ³	pulses/M ³
liquid	pulses/gallon	pulses/liter

Chapter 4

4.0 16 Point Programming

4.1 General Information

The 16 Point menu selection is used when the flow input device gives a non-linear input signal. The unit uses up to 16 different points, as entered by the operator, to form a curve for linearizing the input signal. The setup of the 16 Point menu may tend to be confusing. It is suggested that you review this chapter before attempting to go through the setup menu.

Notes:

- 1) A minimum of three points must be set up.
- 2) If two consecutive input values or K Factors are set to zero, the Flow Computer assumes there are no more points above the points that preceded them. Extrapolation is taken from the last two non-zero points.
- 3) If the input frequency is above the highest or below the lowest frequency programmed, the unit will use the last two points to extrapolate what the K factor should be and the resulting actual flow. Care must be taken that the K factor does not extrapolate to zero. If this happens, the Flow computer will give erroneous readings.
- 4) Frequencies or apparent flows must be entered in ascending order.
- 5) The 16 Point option will not over ride the Cutoff Input Filter frequency entered elsewhere in the Flow Variables menu.
- 6) Press the **C** button when the desired number of points are entered. This will exit the 16 Point setup routine.

3.17 Setting up the Print List

During normal operation, the instrument may be set up to periodically print out, through the RS232 port, the important operating data such as flow rate, temperature, or pressure. The same data that was available for display can be scanned and printed out the serial port of the instrument.

The operator can designate this list that will be printed, and in which order they will be printed. Note: Each item can be selected more than once in the print list even though there is no advantage to doing this.

Use a similar procedure as that used for the display list to set up the list of items, that you would like to data log while the machine is running.

Select the items by pressing the **ENT** key while it is displayed, you can select the items you desire. For example:

DISPLAY	PRESS
Select Item # 1 Flow Rate	ENT
Select Item # 2 Totalizer	ENT
Select Item #3 Temperature	A
Select Item # 3 Pressure	ENT

Continue this process until you have created a list of all the parameters that you would like to print while the instrument is running. Use the **C** key to break out of the menu after your list is created. Make sure that you have set the Print Interval and activated the serial port in the Standby Menu for enabling this feature.

3.18 Print System Setup

This feature is for use in documentation. When this menu item is selected, an entire print out of all the user defined parameters is sent out the RS232 port.

DISPLAY	PRESS
Running . . . Show Data?	<input type="button" value="A"/>
Running . . . Go to standby?	<input type="button" value="A"/>
Continue Pressing <input type="button" value="A"/> until	
Running . . . Print system setup?	<input type="button" value="ENT"/>

A system dump of the parameters through the RS232 serial communications port is performed.

3.19 Examine Hardware

In the running mode parameters cannot be changed but they may be viewed. This is done by using one of the Examine menus (Examine Hardware, Examine Comps and Examine Variables).

This feature is used to examine the hardware setup configuration of the unit. Operation is as follows:

DISPLAY	PRESS
Running . . . Show Data?	<input type="button" value="A"/>
Continue Pressing <input type="button" value="A"/> until	
Running . . . Examine Hardware?	<input type="button" value="ENT"/>

Once selected, use key to scroll through the hardware setup. Use the key to return to Show Data?

3.20 Examine Computations

This feature is used to examine which computation has been selected.

DISPLAY	PRESS
Running . . . Show Data?	<input type="button" value="A"/>
Continue Pressing <input type="button" value="A"/> until	
Running . . . Examine Hardware?	<input type="button" value="A"/>
Running . . . Examine Comps?	<input type="button" value="ENT"/>

Once selected, use key to return to Show Data?

3.21 Examine Variables

This feature is used to examine the various parameters and constants that have been entered.

DISPLAY	PRESS
Running . . . Show Data?	<input type="button" value="A"/>
Continue Pressing <input type="button" value="A"/> until	
Running . . . Examine Comps?	<input type="button" value="A"/>
Running . . . Examine Variables?	<input type="button" value="ENT"/>

Once selected, use , and keys to scroll through the parameters setup. Use the key to return to Show Data?